

Innate Immunity: (I) Molecules & (II) Cells

Stephanie Eisenbarth, M.D., Ph.D.

FOCIS Advanced Immunology Course

2/5/24

M Northwestern Medicine[®]
Feinberg School of Medicine

*Division of Allergy &
Immunology*

*Center for Human
Immunobiology*

Layers of Defense

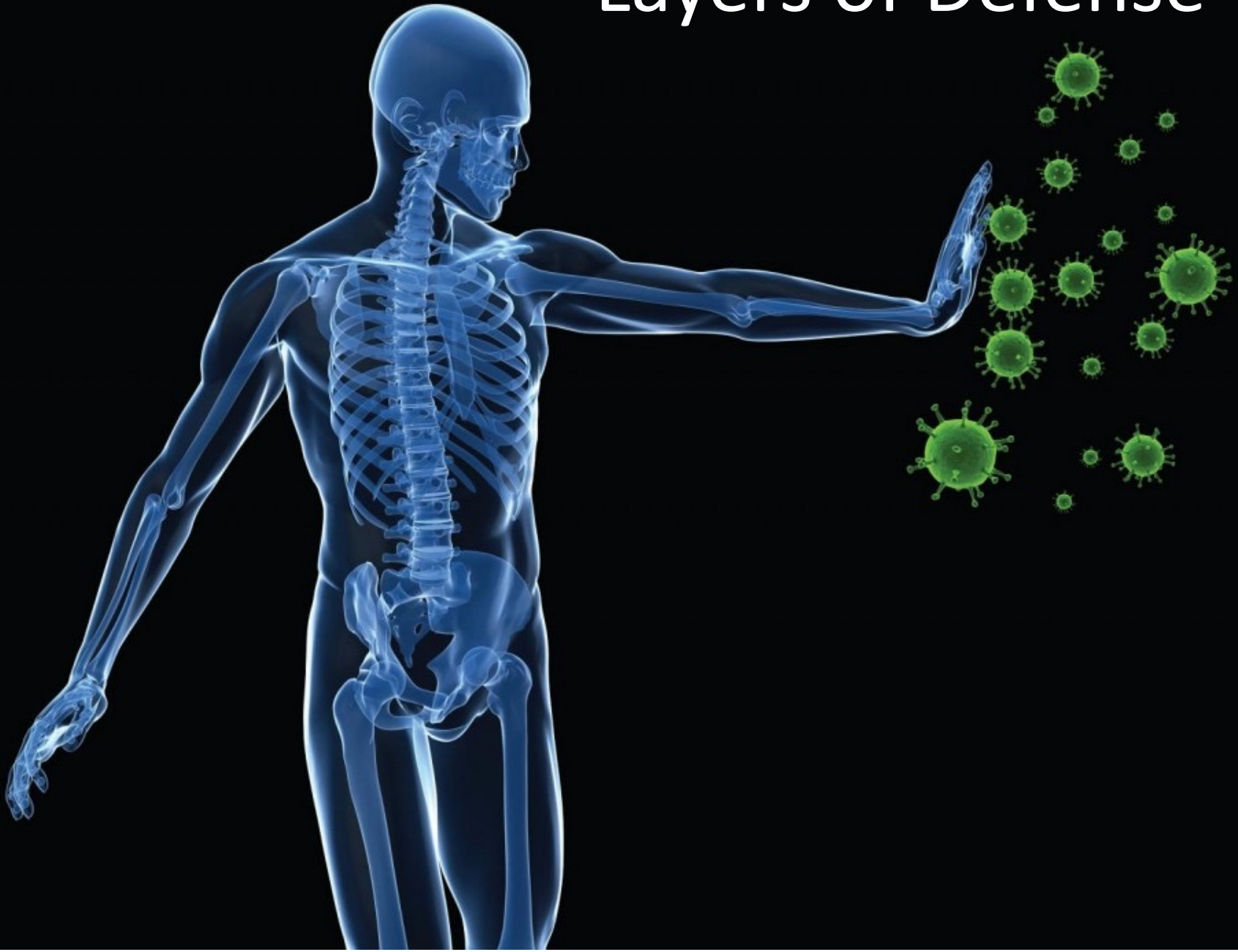

Skin/Mucosa

Barriers, Defensins,
Surfactant, etc.

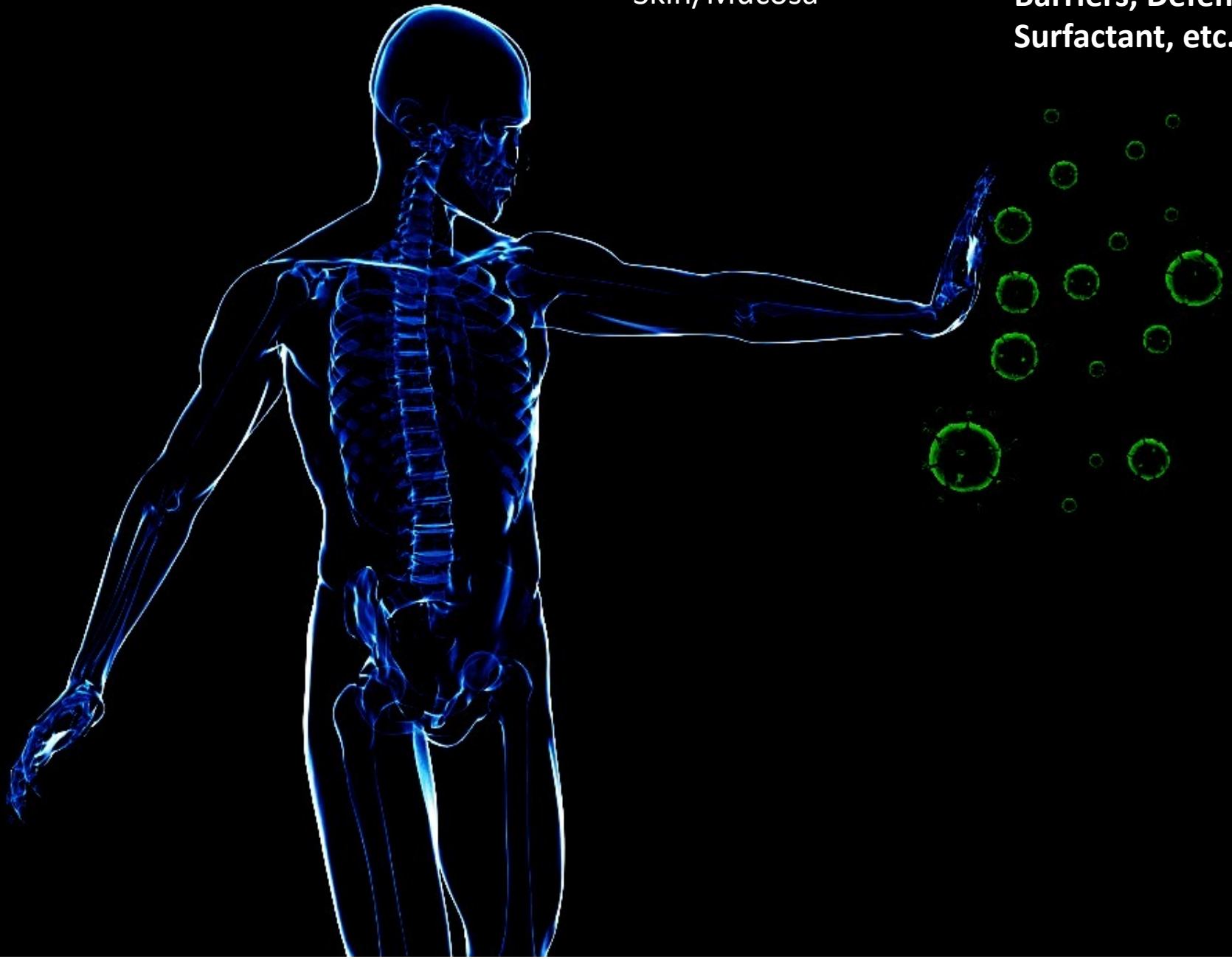

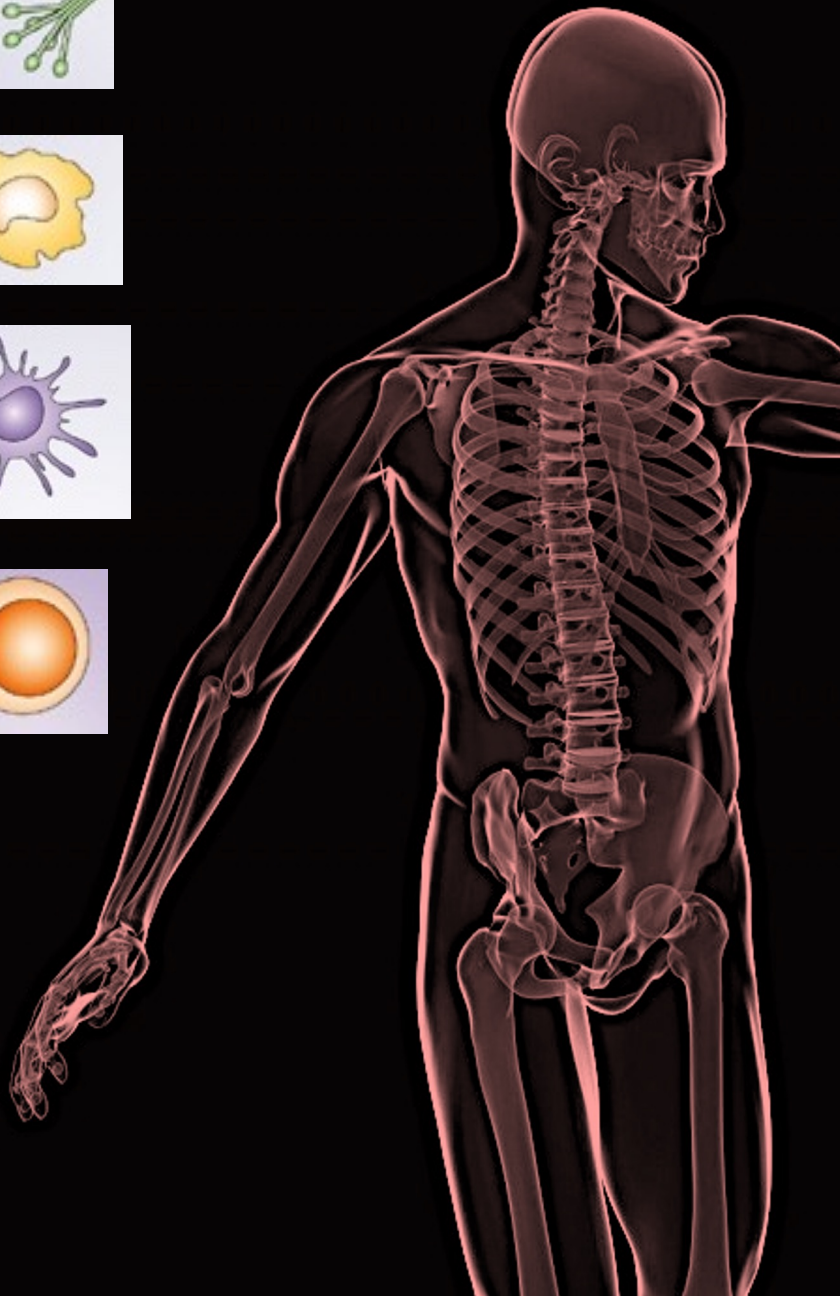
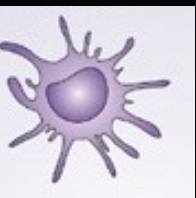

Skin/Mucosa

Complement

Myeloid Cells

Granulocytes

Macrophages

Dendritic cells

Innate lymphocytes

ILC1/NK

ILC2

ILC3

NKT

$\gamma\delta$ T cells

MZB/B1 cells

Barriers

Destruction of foreign material

Removal of targeted or foreign material; antigen presentation

Eliminators and amplifiers of inflammation

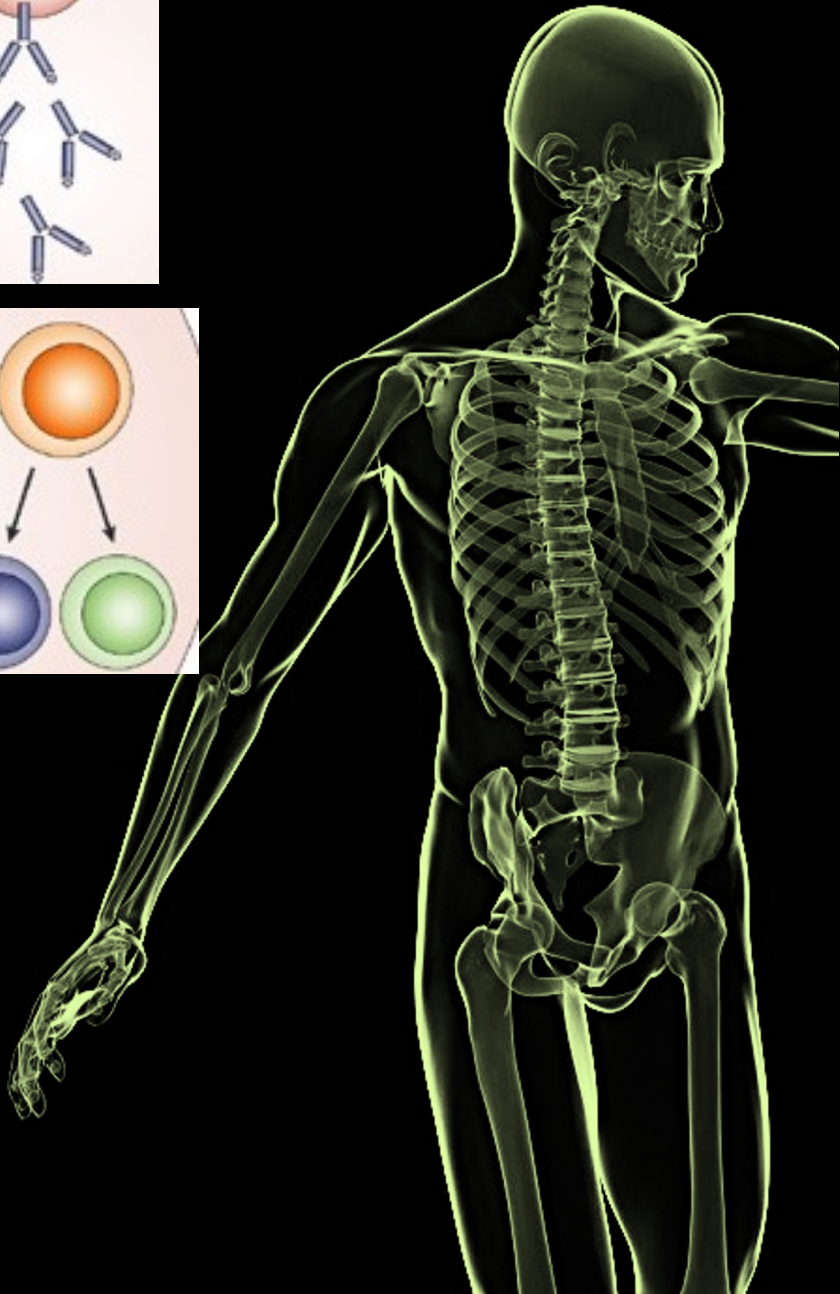
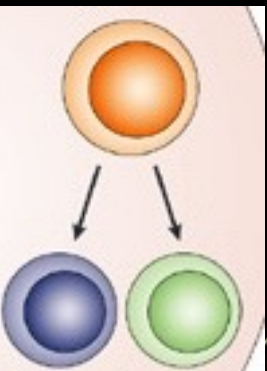
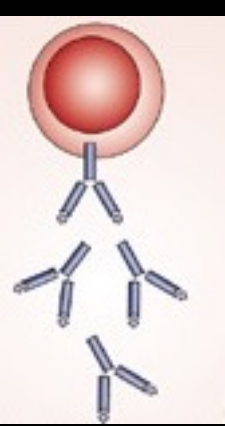

Skin/Mucosa

Complement

Myeloid Cells

Granulocytes

Macrophages

Dendritic cells

Innate lymphocytes

ILC1/NK

ILC2

ILC3

NKT

$\gamma\delta$ T cells

MZB/B1 cells

Lymphocytes

B cells

CD4+ T cells

CD8+ T cells

Barriers

Destruction of foreign material

Removal of targeted or foreign material; antigen presentation

Eliminators and amplifiers of inflammation

Targeting, Killing and Regulation

Constituents of the Immune System

Innate immunity
(rapid response)

Adaptive immunity
(slow response)



B cell

FAST

SLOW

No prior exposure required (*memory)
Ancient immune system (evolved before adaptive immunity)
Receptors encoded in germline
Recognize structures that are shared by classes of microbes

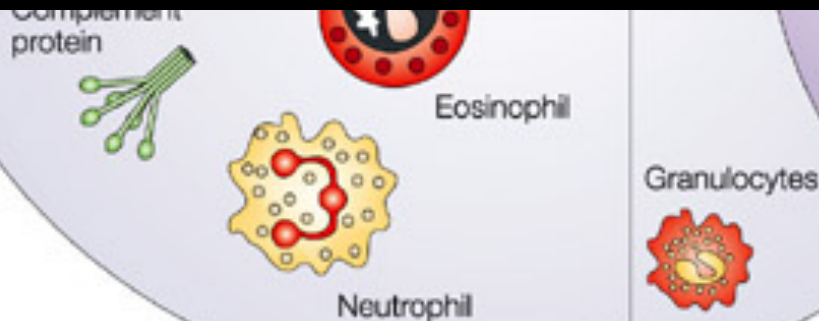
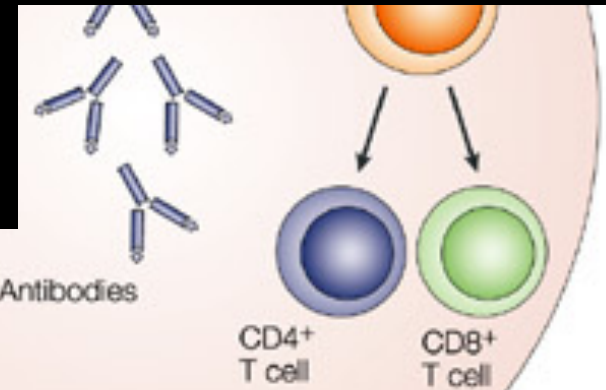

SELF vs. NON-SELF discrimination

What non-self patterns are detected during Listeria infection?

Will discuss at the end...

Part I: Molecules – how they recognize & protect

- Plasma proteins
 - Pentraxins (CRP, SAA, etc.)
 - Collectins & Ficolins
 - Complement
- Pattern recognition receptors
 - TLRs
 - NLRs
 - RLRs
 - DNA sensors
 - CLR

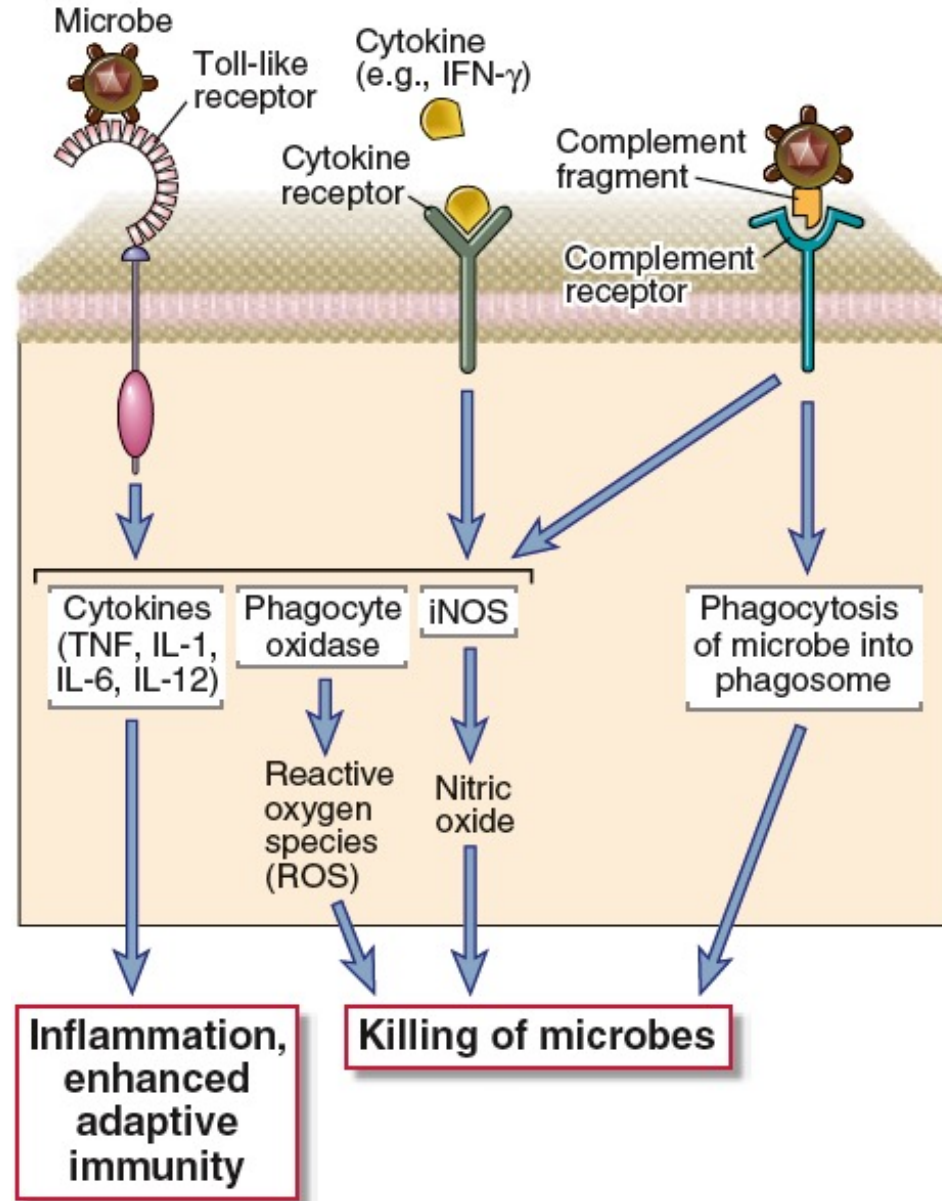

Part I: Molecules – how they recognize & protect

- Plasma proteins
 - Pentraxins (CRP, SAA, etc.)
 - Collectins & Ficolins
 - **Complement**
- Pattern recognition receptors
 - TLRs
 - NLRs
 - RLRs
 - DNA sensors
 - CLR

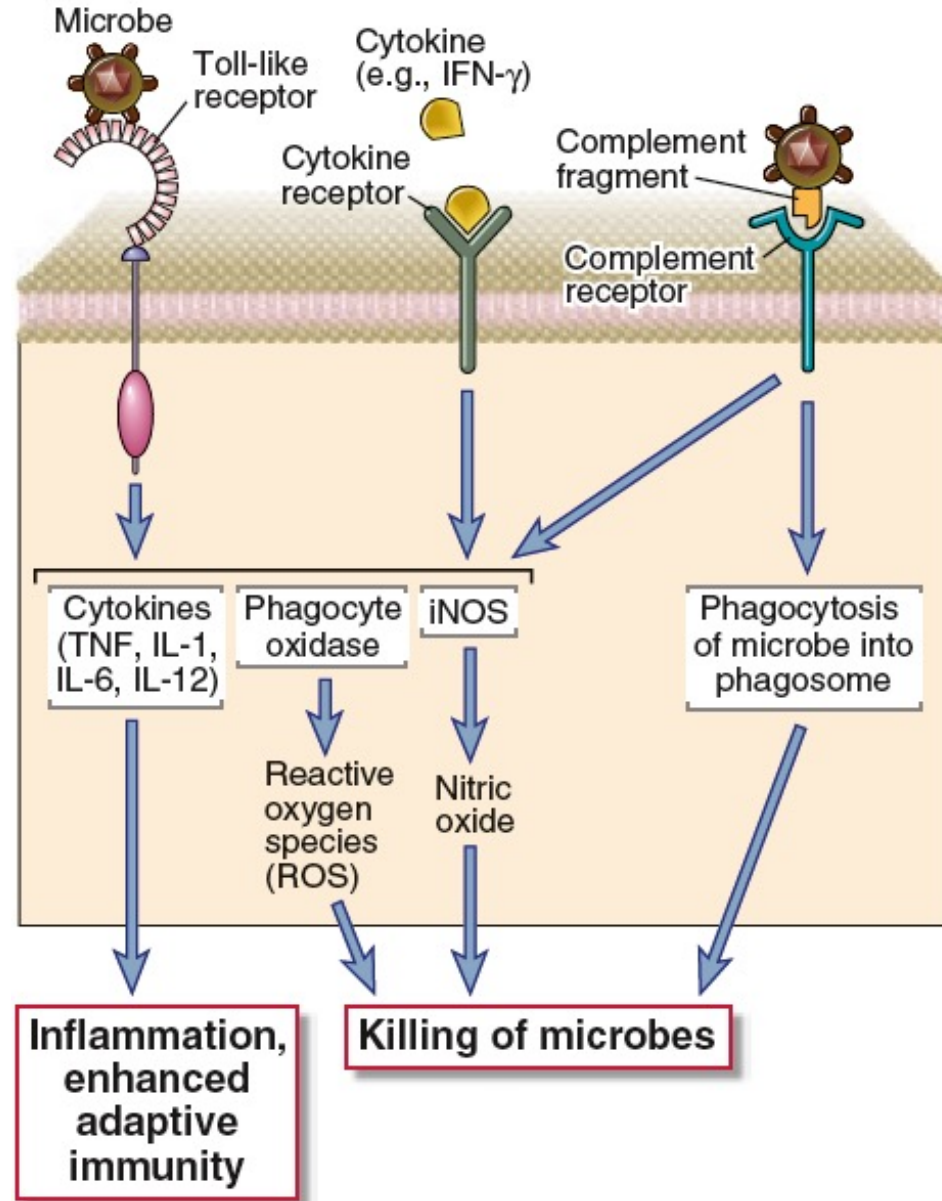

Complement

- Circulating inactive serine protease enzymes
- Cascade of sequential activation

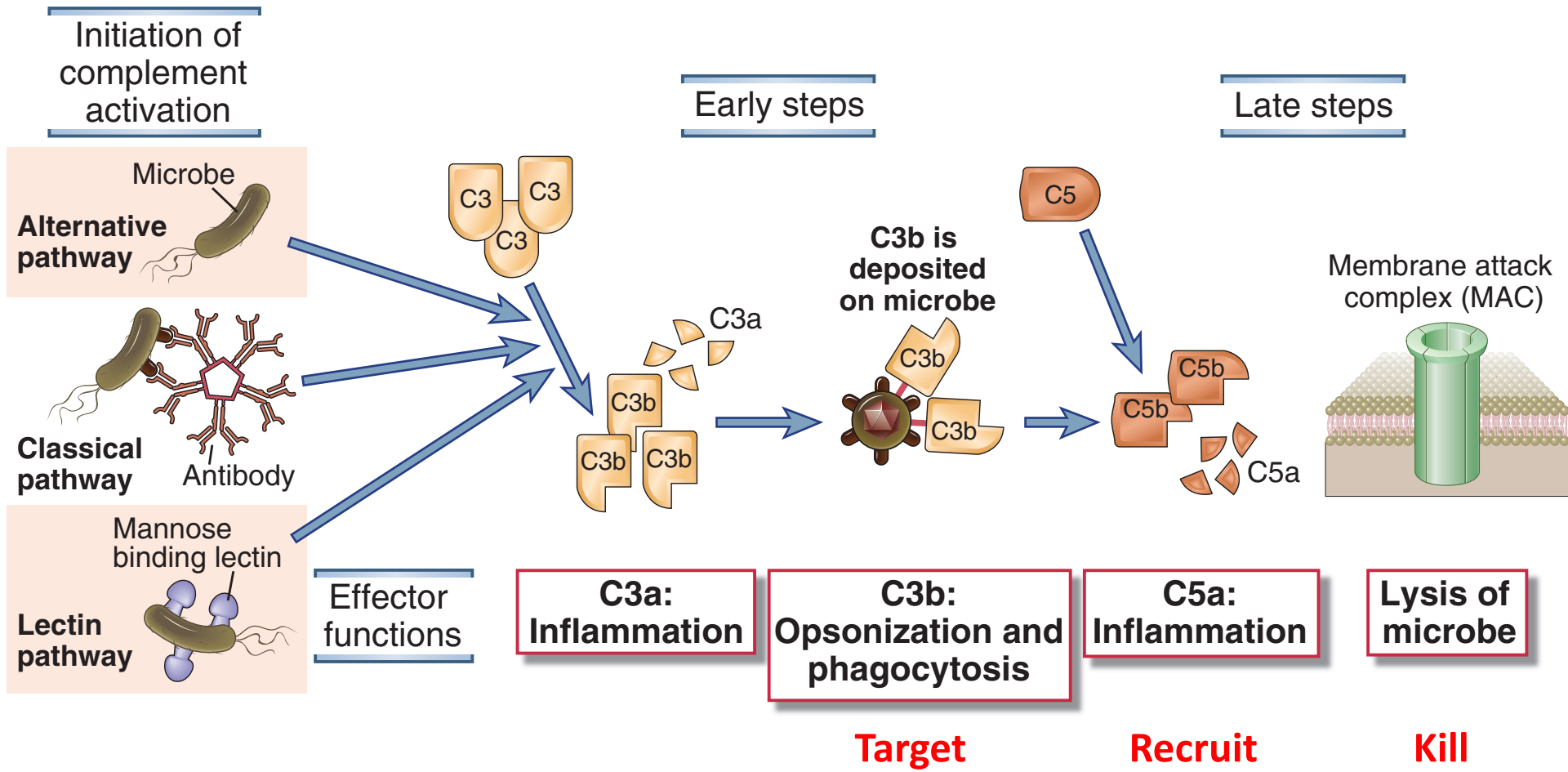

Initiation

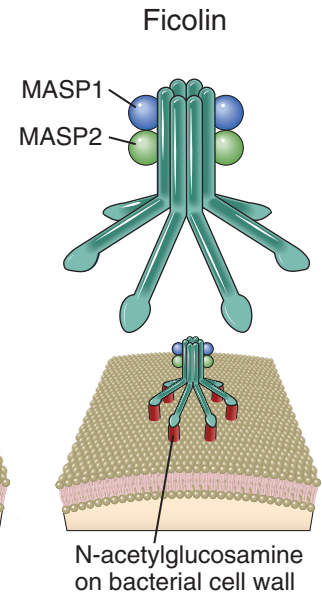
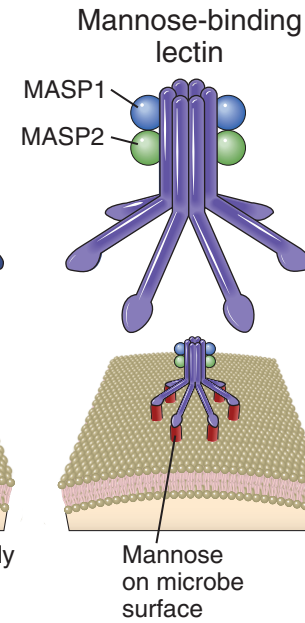
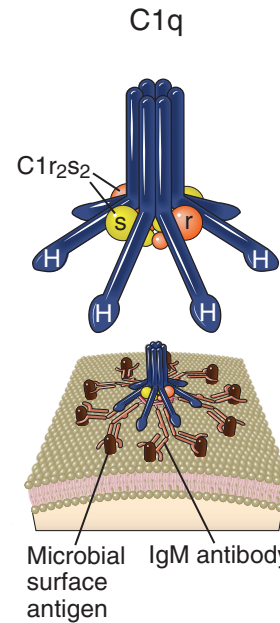
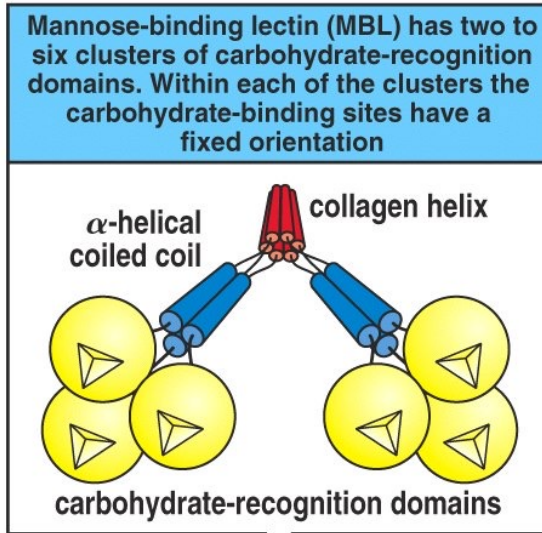

MBL binds with high affinity to mannose and fucose residues with correct spacing

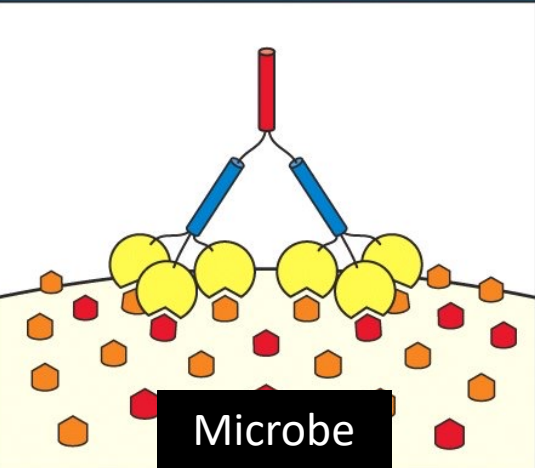

Mannose and fucose residues that have different spacing are not bound by MBL

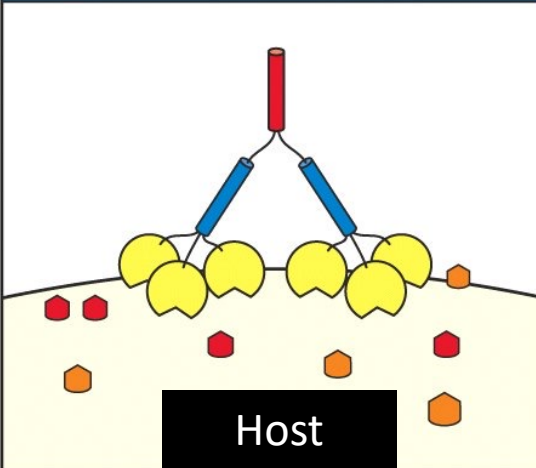

- Classical:** C1q binds IgG/IgM + antigen \rightarrow activates C1s
- MBL:** Collectin/Ficolin bind carbohydrates \rightarrow MASPs
- Alternative:** lack of self \rightarrow spontaneous hydrolysis C3

Name 3 diseases primarily a result of dysregulated complement activity

Under-activity?

Over-activity?

Complement Kills

- Hereditary Angioedema (HAE)
 - C1INH deficiency
 - Non-pitting edema
- Paroxysmal Nocturnal Hemoglobinuria (PNH)
 - CD59 or CD55 (DAF) deficiency
 - Intravascular RBC lysis
- Hemolytic Uremic Syndrome
 - CD46, Factor H/I deficiency (“atypical HUS”)
 - Most common cause of pediatric renal failure (all forms HUS)
- What is eculizumab and how does it work?

Stages at which complement activity is regulated

C1q binding to antigen:antibody complexes activates C1r and C1s

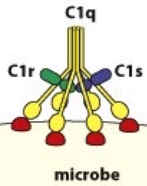

C1 inhibitor (C1INH) dissociates C1r and C1s from the active C1 complex

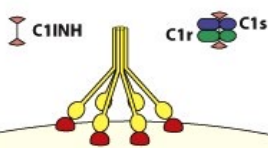

C4b2a is the active C3 convertase, cleaving C3 to C3a and C3b

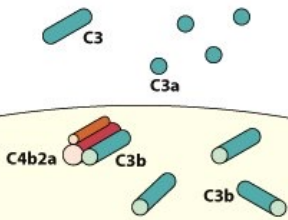

DAF, C4BP, and CR1 displace C2a from the C4b2a complex. C4b bound by C4BP, MCP, or CR1 is cleaved by a soluble protease I to inactive forms C4d and C4c

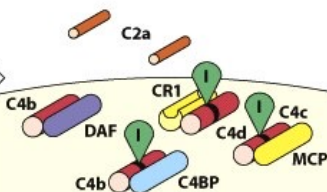

The C5 convertases cleave C5 to C5a and C5b

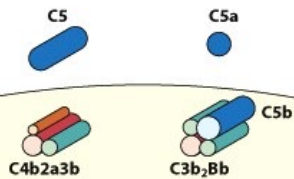

CR1 and H displace C3b. CR1 and H act as cofactors in the cleavage of C3b by I

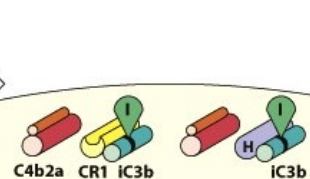

The terminal components of complement form a membrane pore—the membrane-attack complex

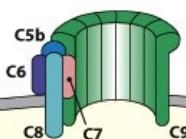

CD59 prevents final assembly of the membrane-attack complex at the C8 to C9 stage

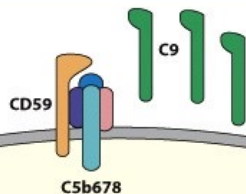

Complement pathway inhibitors

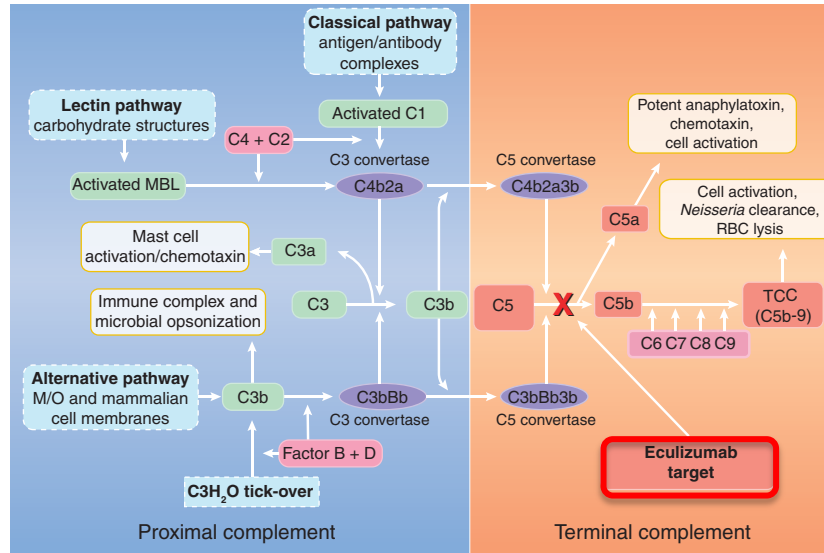
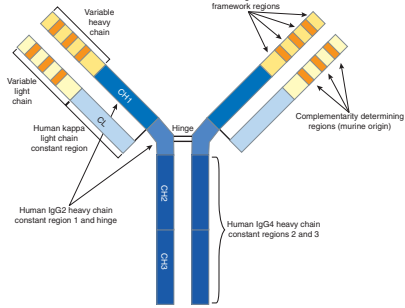

- Soliris (eculizumab) = Recombinant humanized monoclonal antibody directed against C5 → prevents production of terminal complement components
 - 2007: Approved for PNH.
 - 2010: Most expensive drug in the world (~\$410,000/yr).
 - 2011: Approved for aHUS
- Avacopan = C5a receptor inhibitor → reduce PMN chemoattraction & activation
 - 2021: Trialed for ANCA-associated vasculitis
- Berinert, Cinryze = C1-INH replacement therapy
 - Hereditary angioedema
- Transplant rejection, IgA nephropathy, glomerulonephritis, Lupus nephritis, ischemic reperfusion injury, membranous nephropathy...

How do cells recognize invasion?

Pattern recognition receptors distinguish self from non-self

- Detect pathogen directly
 - Pathogen Associated Molecular Patterns (PAMPs)
 - Conserved, foreign structures
 - Composition & location
 - LPS, Flagellin, CpG, dsRNA
- Detect damage microbes inflict
 - Damage Associated Molecular Patterns (DAMPs)
 - When cells die they release or expose molecules not normally seen
 - Uric acid crystals, ATP, Alarmins (IL-33, HMGB1)
 - Loss of normal self molecules
 - Sialic acid

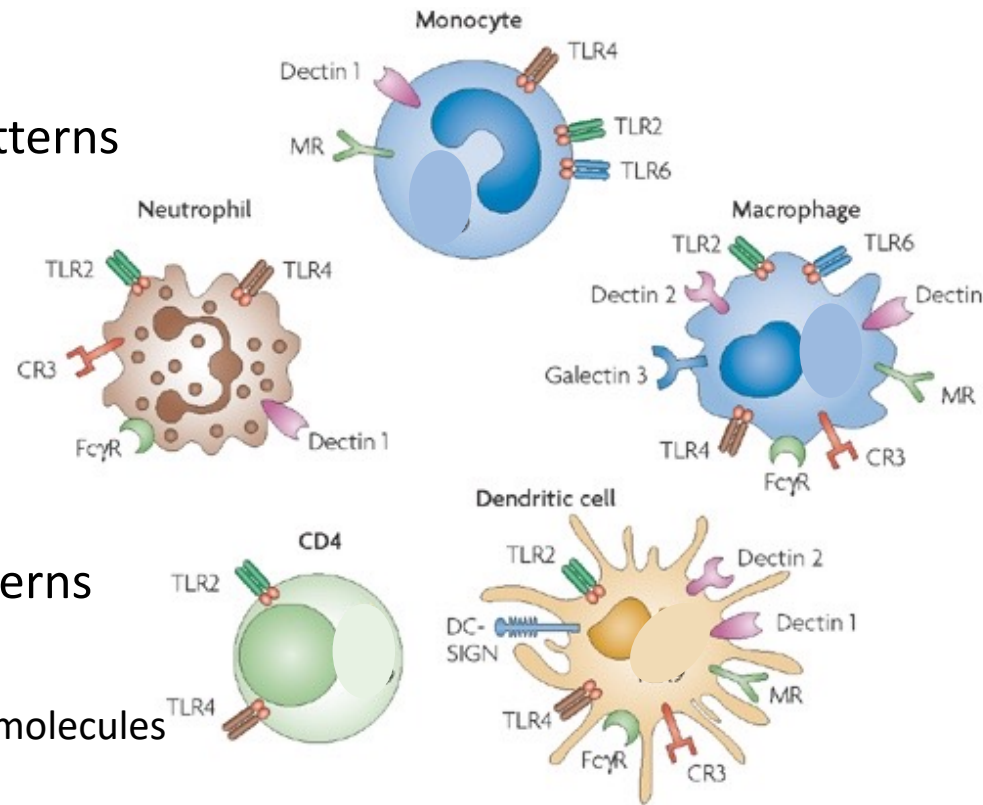

NOTE: Not all cells express the same repertoire of PRRs

PRRs survey different cellular compartments

1. **TLR** (Toll-like Receptors) - PAMPs extracellular or phagocytosed
2. **CLR** (C-type Lectins) – Carbohydrates/glucans
3. **NLR** (NOD-like Receptors) – Cytosolic PAMPs & DAMPs
4. **RLR** (RIG-I-like Receptors) – Cytosolic Viral RNA
5. **CDS** (Cytosolic DNA Sensors) – Cytosolic nucleotides

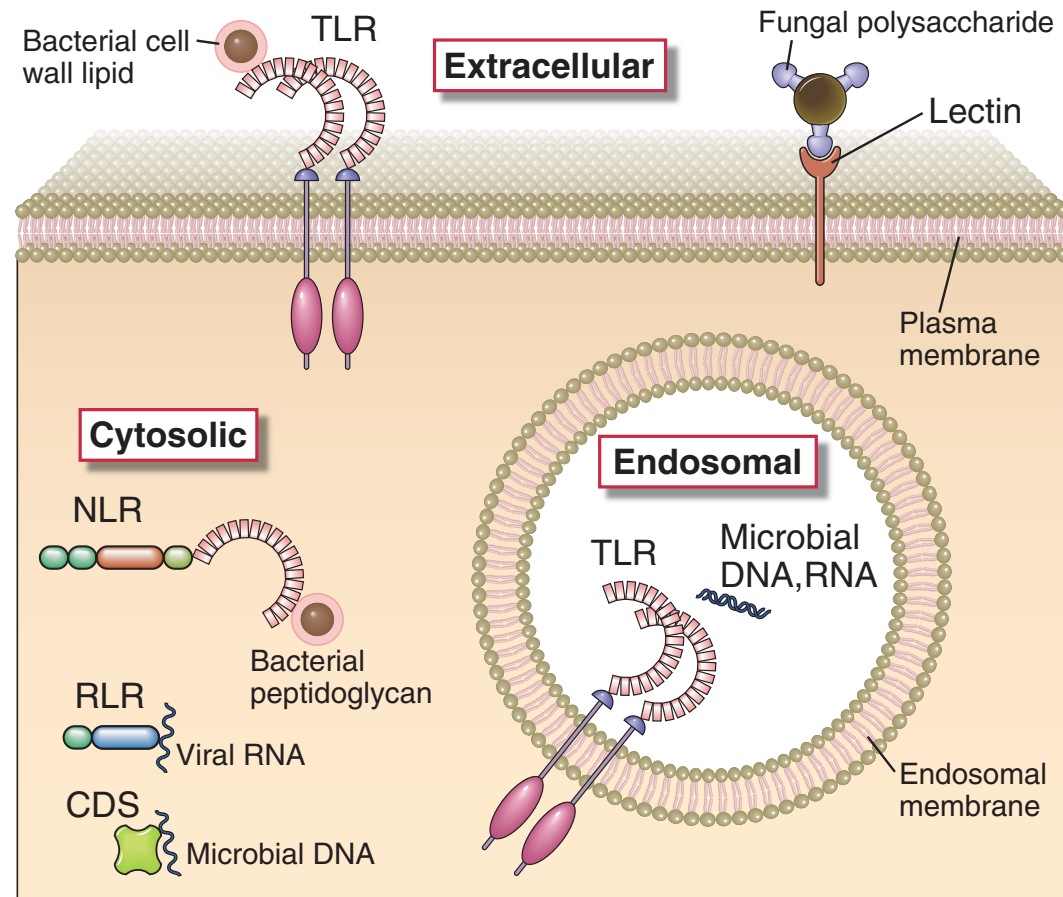

Macrophage, dendritic cell, epithelial cell, etc.

Toll-like Receptors (TLRs): specificity

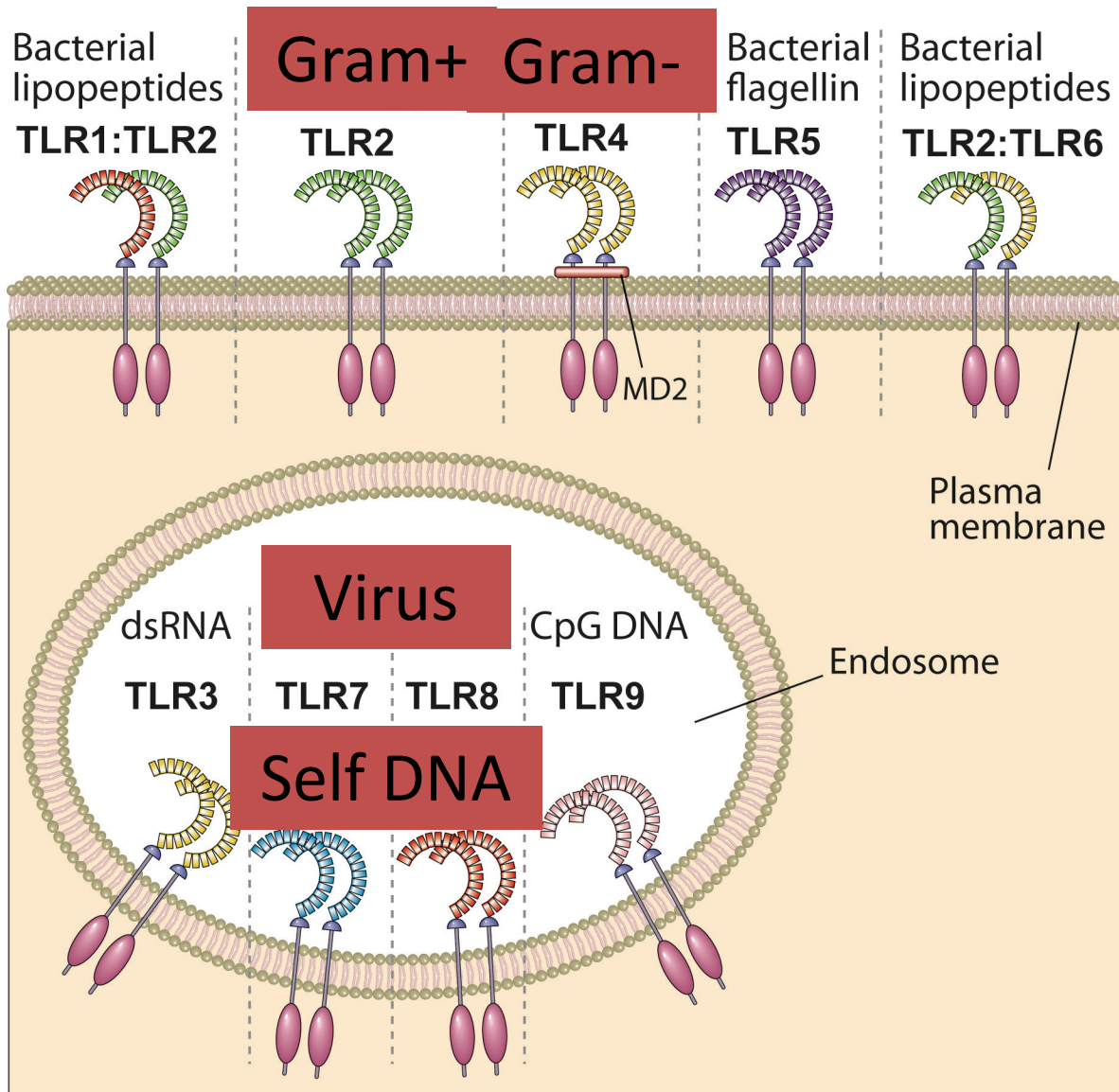

- 13 TLRs humans/mice
- Germ-line encoded
- PAMPs from bacteria, viruses & fungi
 - Lipids, lipoproteins and nucleic acids
- Specificities are subject to natural selection by infectious organisms
- Different sets of TLRs are expressed on different cells

TLRs use two signaling pathways

MyD88 → NF-κβ

TRIF → IRFs

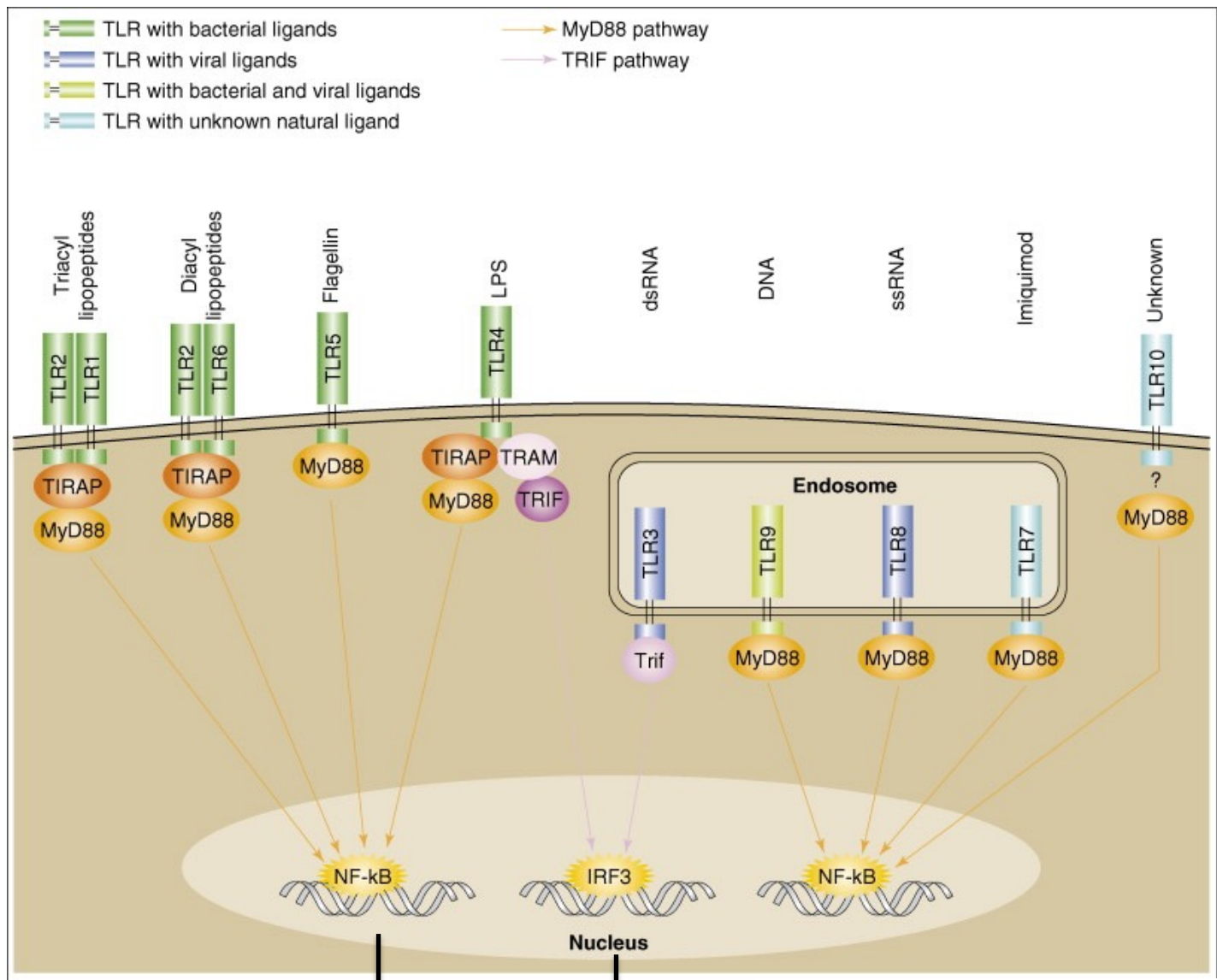

Liu et al Trends Molec. Med. 2007

Pro-inflammatory cytokine induction
Changes in surface molecules

Anti-viral state
IFNs

TLRs & Disease

- Mutations in TLR3 → HSV encephalitis
- Mutations in MyD88 → invasive bacterial infections

Clinical uses:

- Numerous TLR agonists and antagonists under development for cancer, vaccines (more in lecture 2), autoimmunity, etc.
- TLR ligands = vaccine adjuvants
 - CpG
 - MPL (Monophosphoryl Lipid A)
- Aldara (an imidazoquinoline) = TLR7 agonist in clinical use topically for warts and pre-cancerous lesions in skin
- Excessive TLR4 triggering → septic shock
 - TLR4 antagonists in Phase III trials

NOD-like receptors (NLRs)

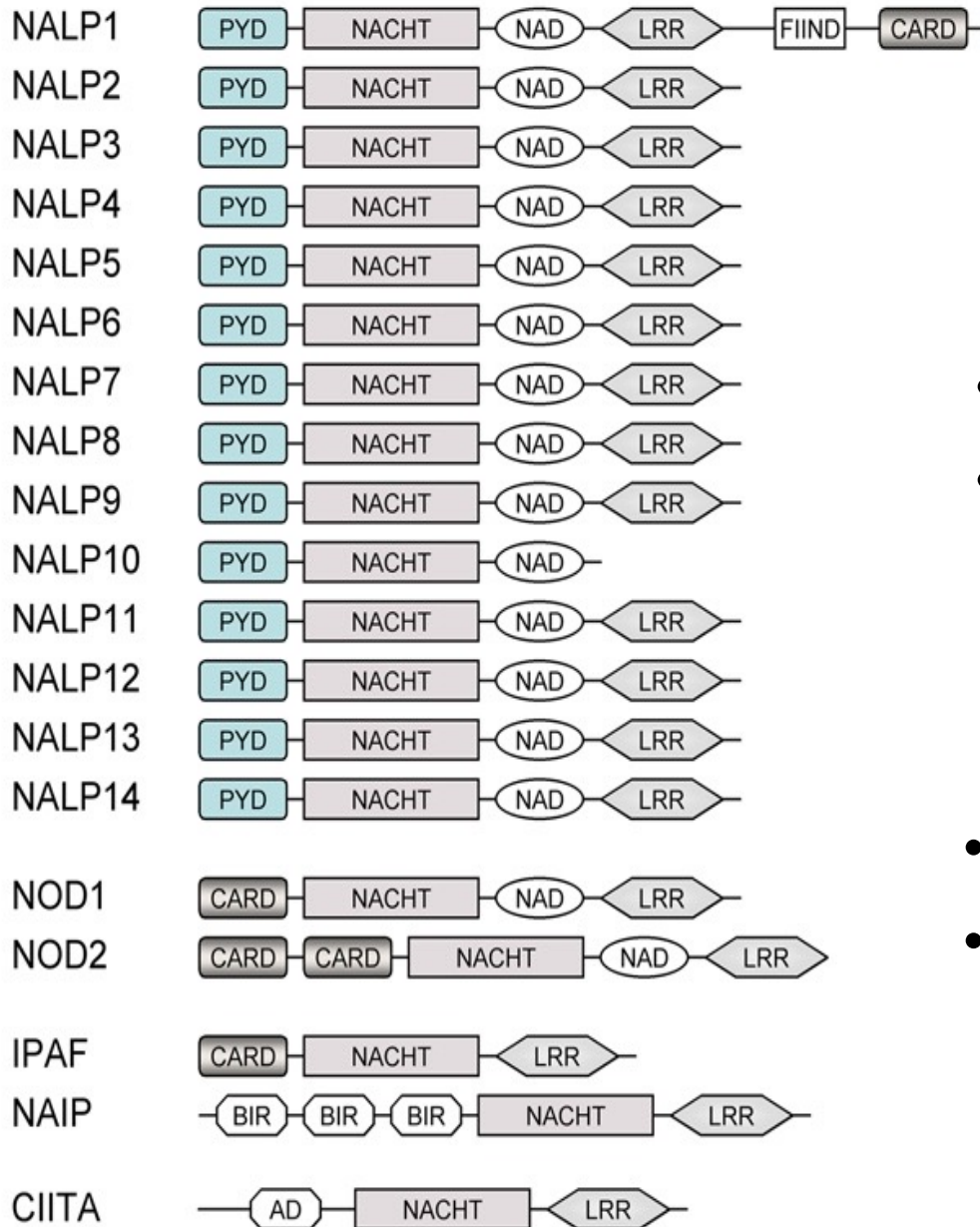

- Cytosolic PRRs
- Triggered by numerous stimuli
 - Membrane disruption
 - Cytosolic PAMPs
 - DAMPs
- “Backup detection system”
- Activate inflammasomes...

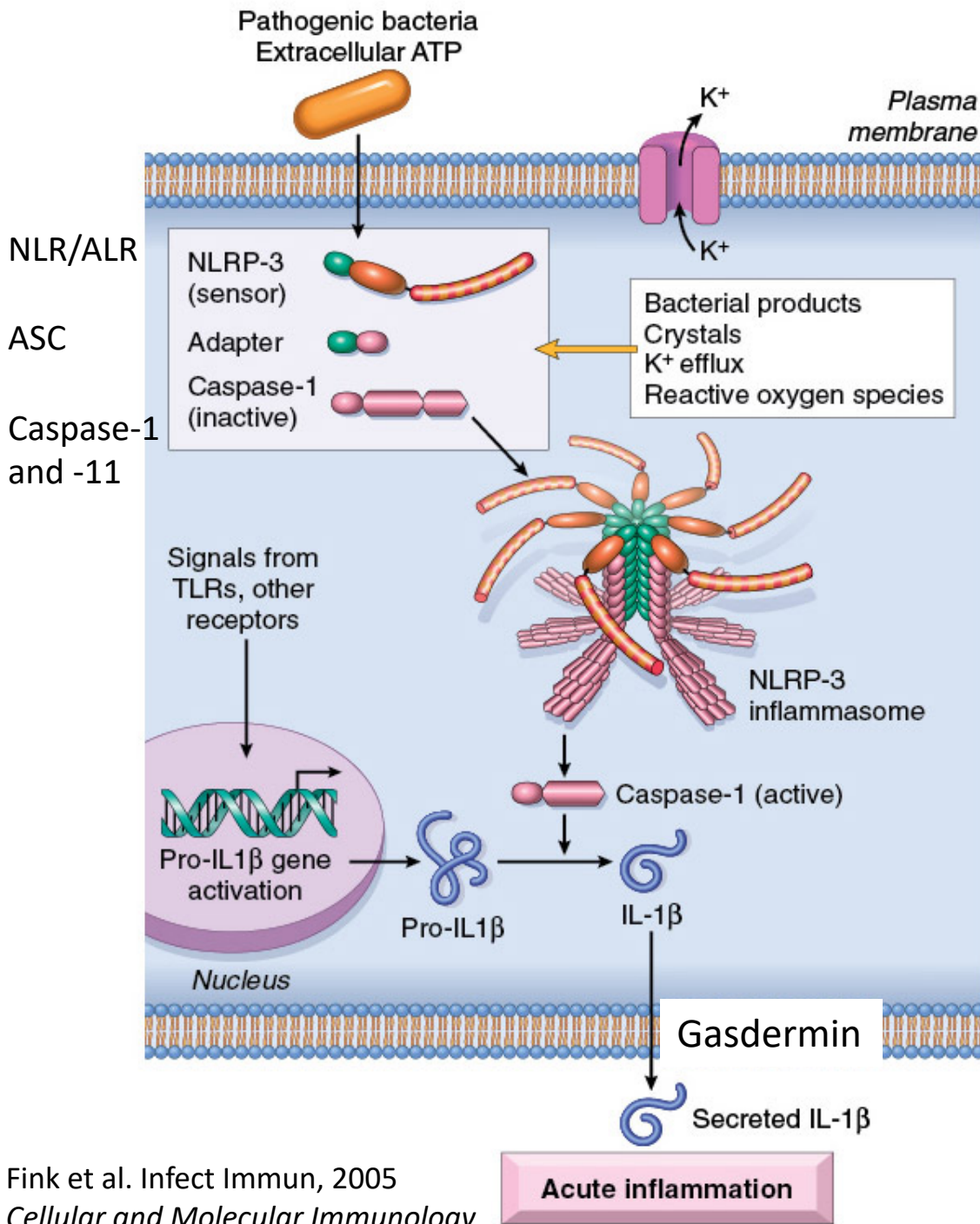

Inflammasomes: primary mechanism of regulating release of IL-1 β & IL-18, Pyroptosis

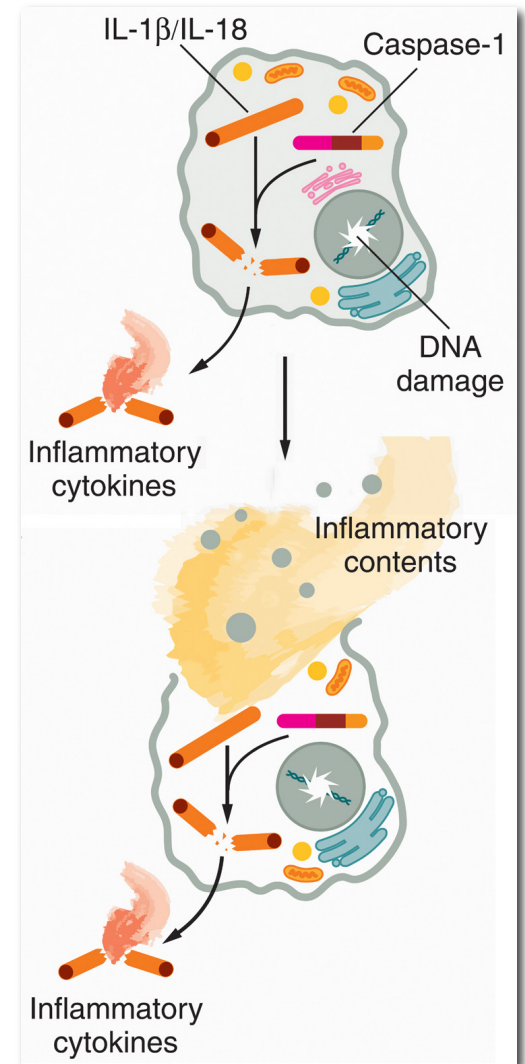

Autoinflammatory diseases

- Gout
 - Uric acid crystals
 - IL-1 pathology
- Periodic Fever Syndromes
 - Nlrp3
- Crohn's Disease
 - NOD2
 - Mixed type disease

Crohn's

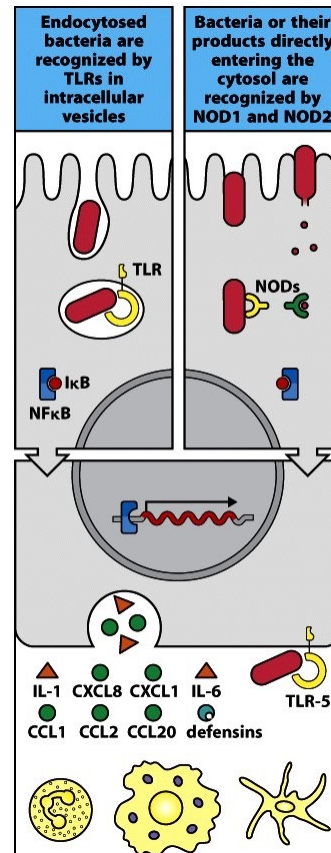

Gout Cyropyrinopathies

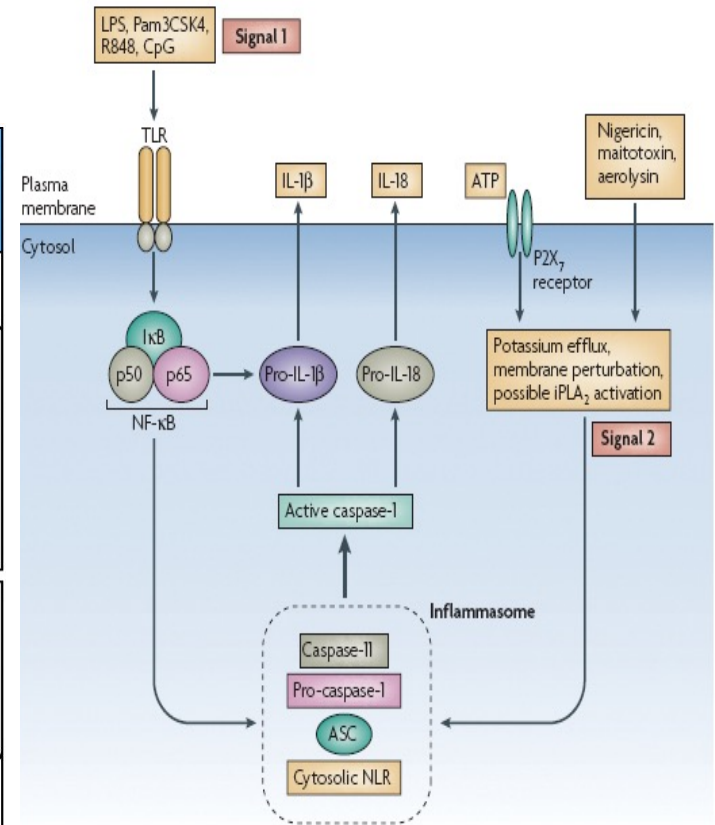

Immunodeficiency

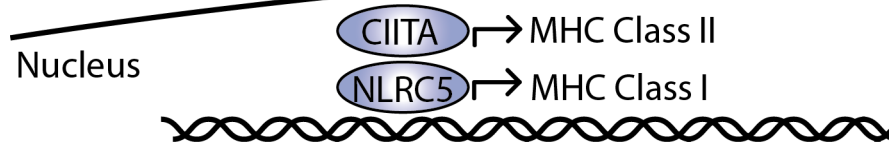

RLRs: cytosolic dsRNA

- RIG-I, LGP2 & MDA5
 - dsRNA is an obligatory replication intermediate for RNA viruses
 - dsRNA with exposed triphosphate @ 5' end (capped on human mRNA)
 - RNA-DNA heteroduplex, Long dsRNA, Blunt end short dsRNA
- DExD/H-box family helicases: CARD & helicase domains
 - DNA & RNA sensing
 - DDX3, DDX60
- MAVS
 - Signaling

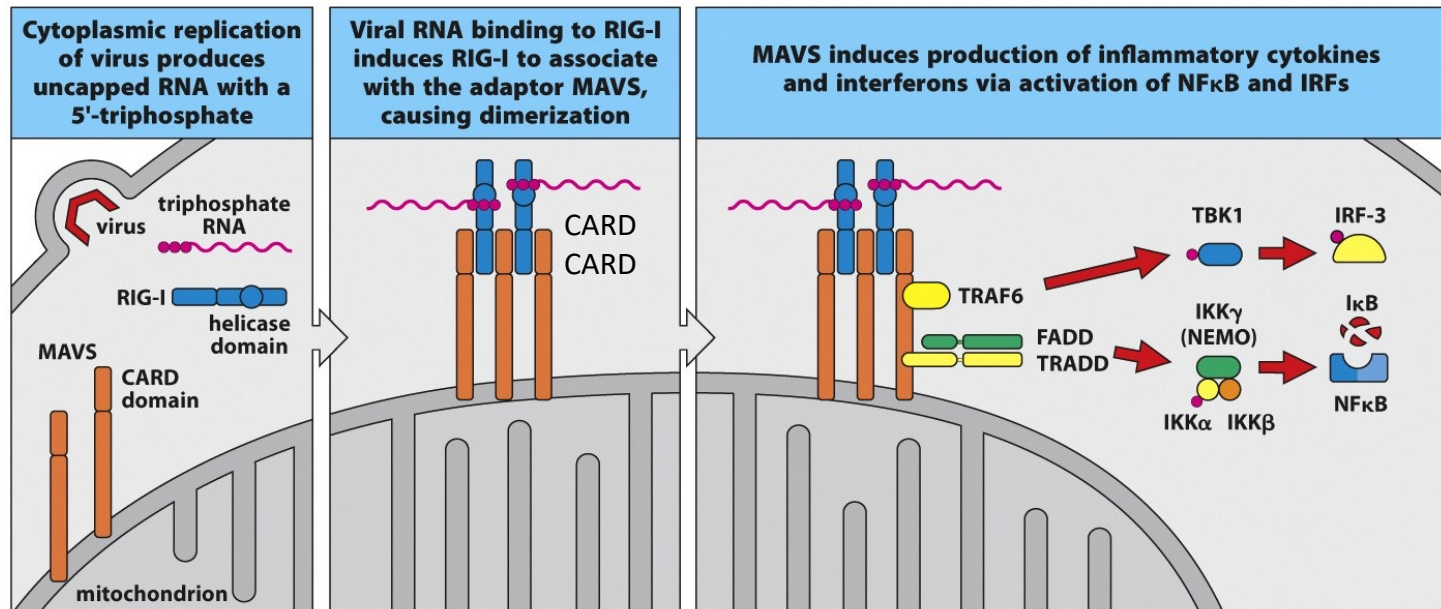

Cytosolic DNA Sensors (CDS)

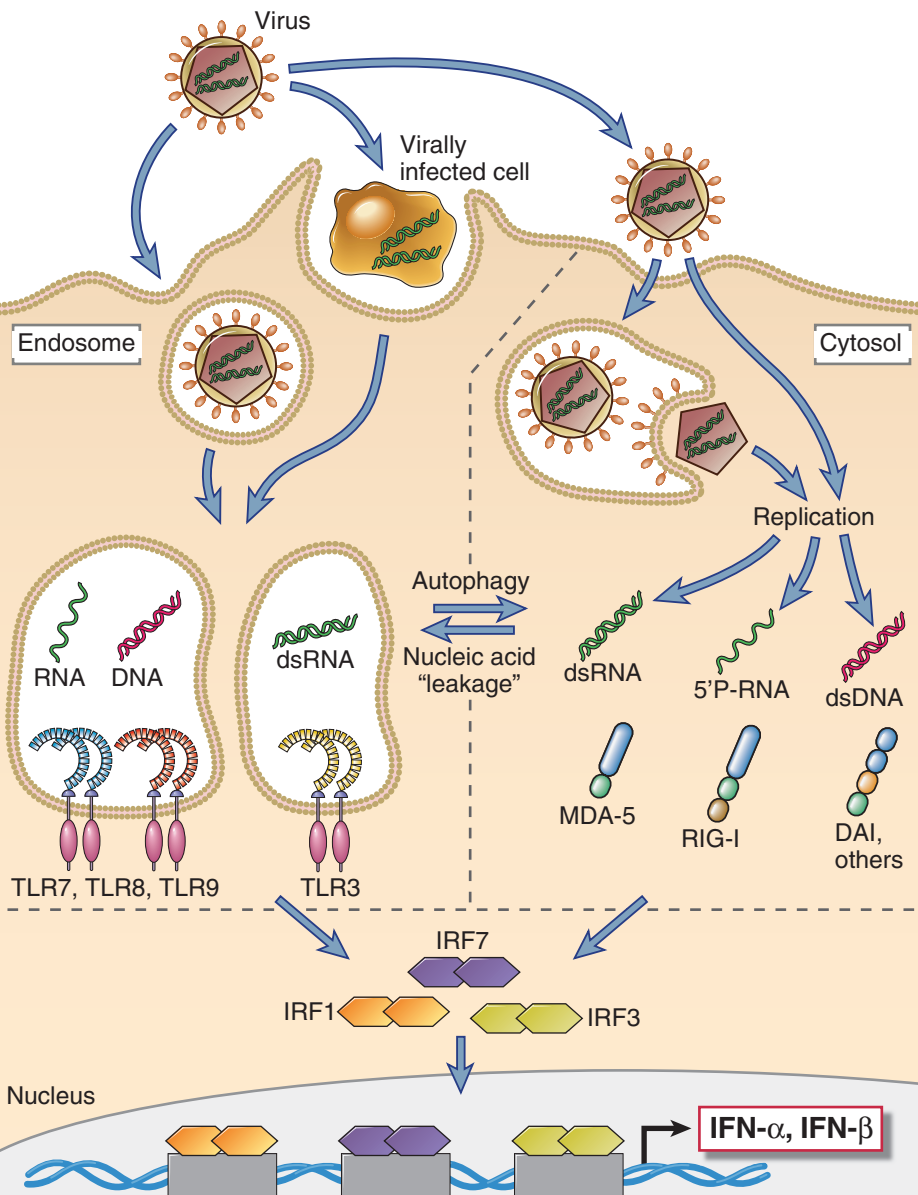

Transform viral DNA into RLR ligands
Recognize long DNA structures
Enzymatically produce CDS ligands to recruit multiple pathways

- DNA in cytosol → RNAPolIII → dsRNA → RLRs
- ALRs (Aim2, IFI16)
 - dsDNA
- DAI
 - dsDNA
- DDX41, DHX9, DDX36...
- cGAS
 - dsDNA
- All induce type 1 IFN!

STING (stimulator of type I IFN genes) pathway

cGAS = DNA dependent cyclase (enzyme) → cGAMP
→ STING → IFNs

STING/cGAS important checkpoint in transformation and cancer immunity

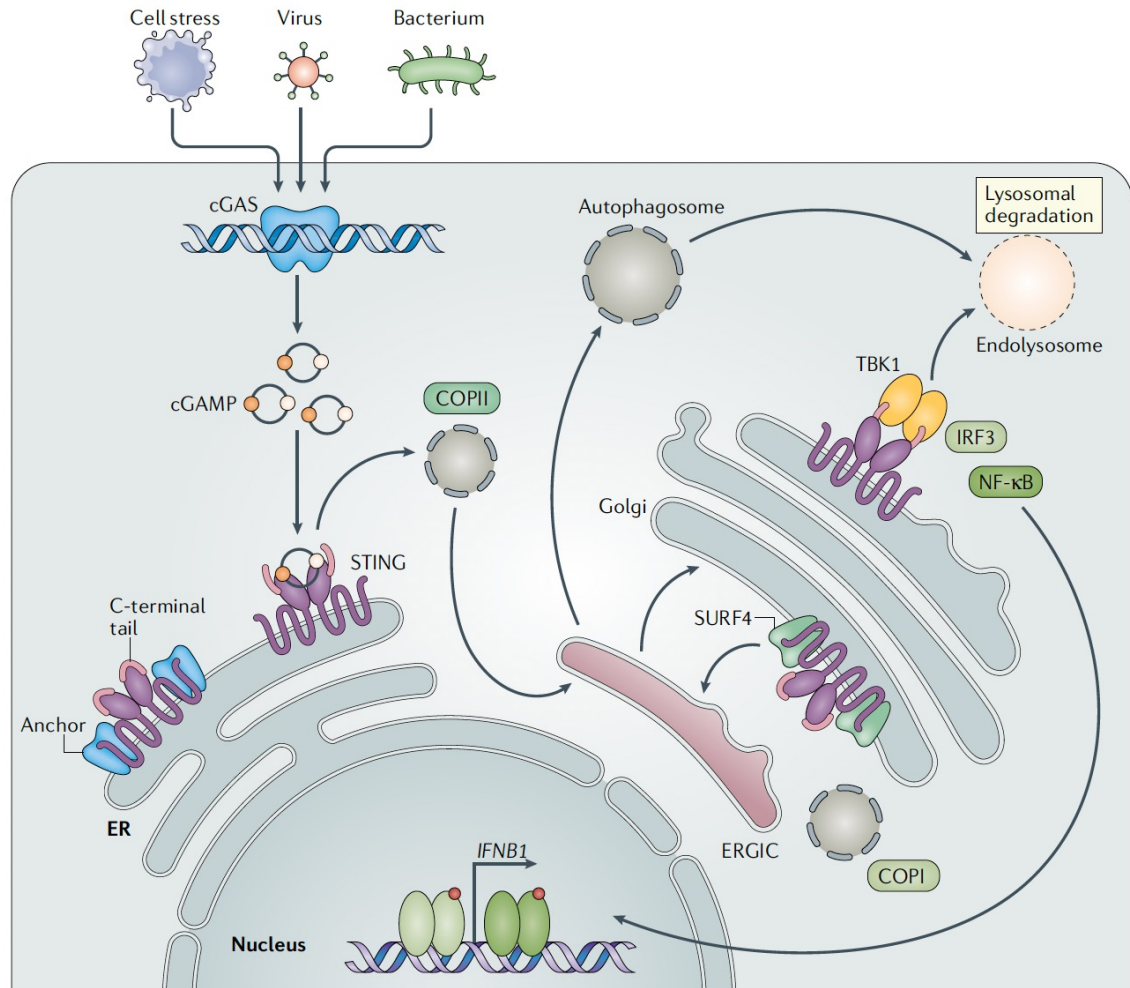

What non-self patterns are detected during *Listeria* infection?

Intracellular Gram+ flagellated bacteria

- Extracellular → Phagocytose → Escape into cytosol
- TLR2 (PGN)
- NOD1/NOD2 (cytosolic PGN)
- TLR5 (flagellin)
- Nlrp3 (LLO)
- cGAS & RIG-I (bacterial nucleic acids)
- PRRs can recognize the same pathogen without recognizing the same PAMP

Anti-viral state

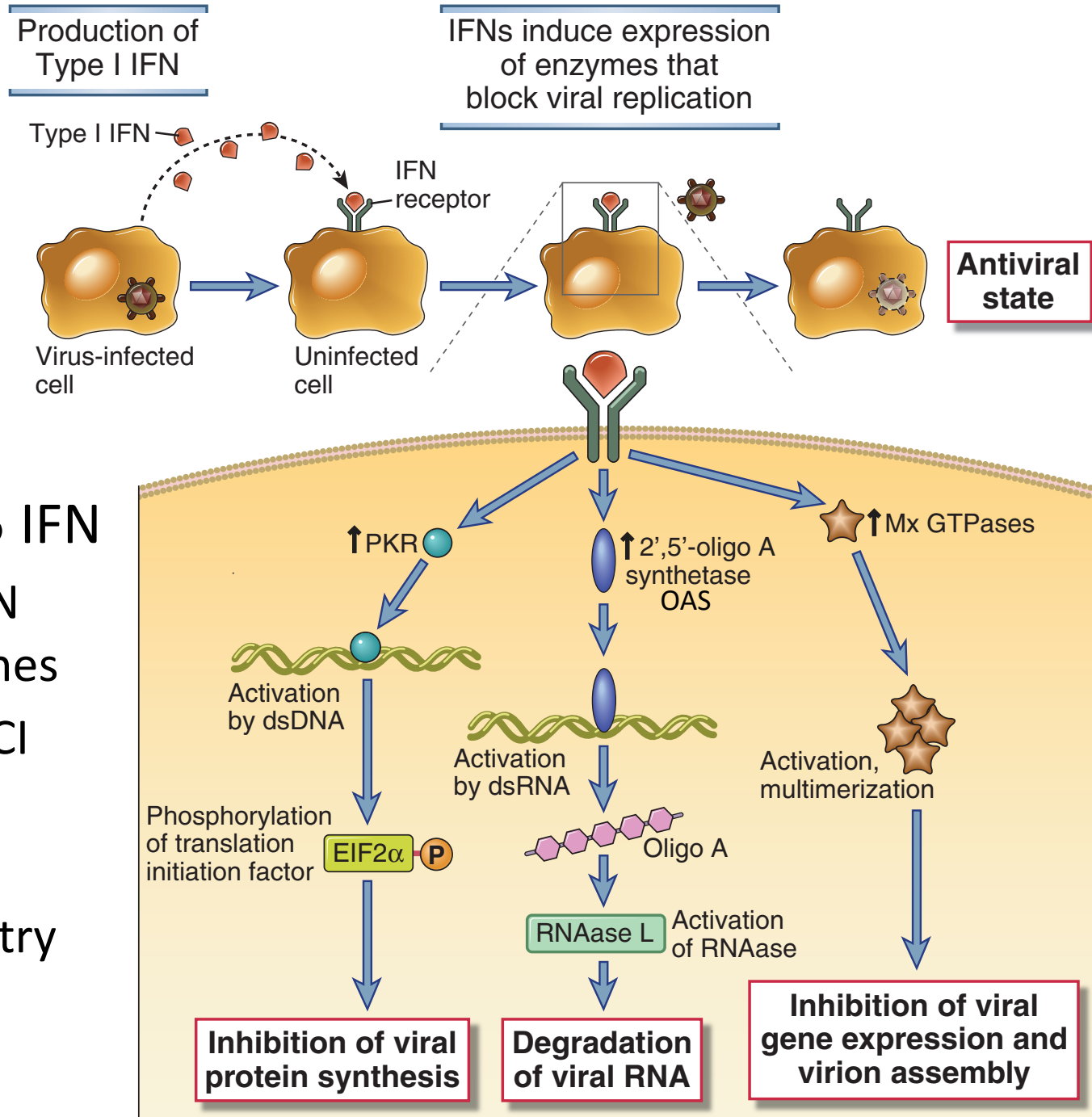

CDS & Disease

- Autoimmune disease
 - PRR-promoted adaptive immune dysregulation (often with autoantibodies)
 - Example: TLR7 & Lupus
- Autoinflammatory disease
 - Sterile innate cell-driven inflammation without significant adaptive immune dysregulation
 - Example: NLR-mediated IL-1 over-production
- Hyperactivation of CDS associated with an overlap category: Type 1 Interferonopathies (enhanced Type 1 IFNs)
 - Aicardi-Goutieres Syndrome
 - SAVI (STING-associated vasculopathy with onset in infancy)
 - Autoinflammation and Autoimmunity

Autoimmunity ≠ Autoinflammatory





T/B cell mediated vs. innate inflammation (cytokines, granulocyte activity, etc.)

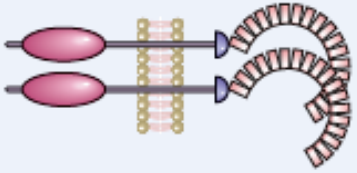
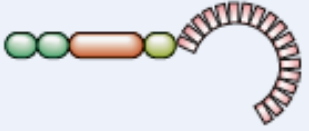

How do we treat autoimmune diseases? How do we diagnose?

How do we treat autoinflammatory diseases? How do we diagnose?

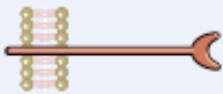
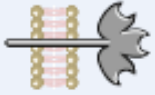
Questions to ponder...

- How does the innate immune system recognize Helminths? Allergens? Transplanted organs? Self tissue?
- Do PRRs recognize/respond to commensal bacteria?

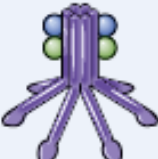
Pattern Recognition Receptors	Location	Specific Examples	PAMP/DAMP Ligands
Cell-Associated			
Toll-like receptors (TLRs) 	Plasma membrane and endosomal membranes of dendritic cells, phagocytes, B cells, endothelial cells, and many other cell types	TLRs 1-9	Various microbial molecules including bacterial LPS and peptidoglycans, viral nucleic acids
NOD-like receptors (NLRs) 	Cytosol of phagocytes, epithelial cells, and other cells	NOD1/2 NLRP family (inflammasomes)	Bacterial cell wall peptidoglycans Intracellular crystals (urate, silica); changes in cytosolic ATP and ion concentrations; lysosomal damage
RIG-like receptors (RLRs) 	Cytosol of phagocytes and other cells	RIG-1, MDA-5	Viral RNA
Cytosolic DNA sensors (CDSs) 	Cytosol of many cell types	AIM2; STING-associated CDSs	Bacterial and viral DNA
C-type lectin-like receptors (CLRs) 	Plasma membranes of phagocytes	Mannose receptor Dectin	Microbial surface carbohydrates with terminal mannose and fructose Glucans present in fungal cell walls
Scavenger receptors 	Plasma membranes of phagocytes	CD36	Microbial diacylglycerides
<i>N</i> -Formyl met-leu-phe receptors 	Plasma membranes of phagocytes	FPR and FPRL1	Peptides containing <i>N</i> -formylmethionyl residues

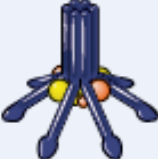
Soluble			
Pentraxins 	Plasma	C-reactive protein	Microbial phosphorylcholine and phosphatidylethanolamine
Collectins 	Plasma	Mannose-binding lectin	Carbohydrates with terminal mannose and fructose
	Alveoli	Surfactant proteins SP-A and SP-D	Various microbial structures
Ficolins 	Plasma	Ficolin	<i>N</i> -Acetylglucosamine and lipoteichoic acid components of the cell walls of gram-positive bacteria
Complement 	Plasma	Various complement proteins	Microbial surfaces

Questions?

Discussion & Break

Innate Immunity: (II) Cells

Stephanie Eisenbarth, M.D., Ph.D.

M Northwestern Medicine[®]
Feinberg School of Medicine

*Division of Allergy &
Immunology*

*Center for Human
Immunobiology*

Part II: Cells (aka the Sentinels)

CCL19

- Granulocytes
 - Neutrophil, Eosinophil, Basophil, Mast cell
- Monocytes/macrophages
- Dendritic cells
- Innate lymphoid cells

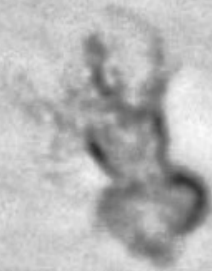

Myeloid Cells

- Recognize microbes
 - PRRs
 - Complement coating
 - Antibody coating
- Ingest & destroy microbes
- Kill infected/injured cells
- Regulate tissue homeostasis
- Antigen presentation
 - Help T cells







Cell		Activated function	Cell		Activated function
Macrophage		Phagocytosis and activation of bactericidal mechanisms Antigen presentation	Eosinophil		Killing of antibody-coated parasites
					
Dendritic cell		Antigen uptake in peripheral sites Antigen presentation	Basophil		Promotion of allergic responses and augmentation of anti-parasitic immunity
					
Neutrophil		Phagocytosis and activation of bactericidal mechanisms	Mast cell		Release of granules containing histamine and active agents
					

Figure 1.4 Janeway's Immunobiology, 8ed. (© Garland Science 2012)

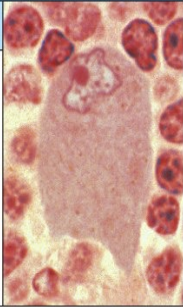
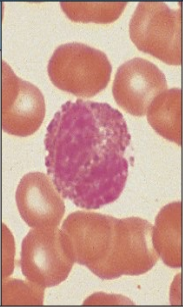
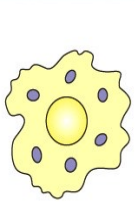
What about these cells?

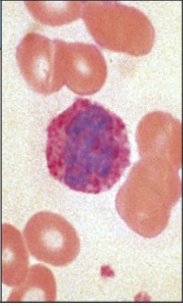
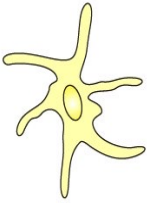

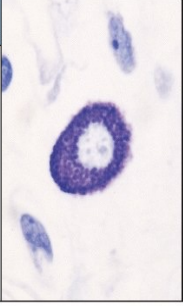
- Function with T cells and B cells
 - Some require antibody as a “receptor”
 - Can also use PRRs
- What do they fight?
 - Ectoparasites/large pathogens
 - Allergens!!?!
- How do they fight?
 - Digest
 - Expel/flush

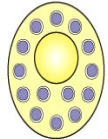



Cell		Activated function	Cell		Activated function
Macrophage		Phagocytosis and activation of bactericidal mechanisms Antigen presentation	Eosinophil		Killing of antibody-coated parasites
Dendritic cell		Antigen uptake in peripheral sites Antigen presentation	Basophil		Promotion of allergic responses and augmentation of anti-parasitic immunity
Neutrophil		Phagocytosis and activation of bactericidal mechanisms	Mast cell		Release of granules containing histamine and active agents

Figure 1.4 Janeway's Immunobiology, 8ed. (© Garland Science 2012)

Two pathways for macrophage development

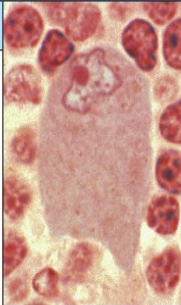
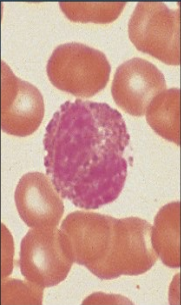
During inflammatory reactions

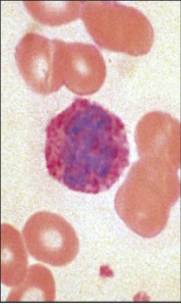

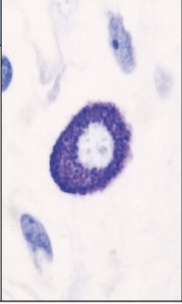
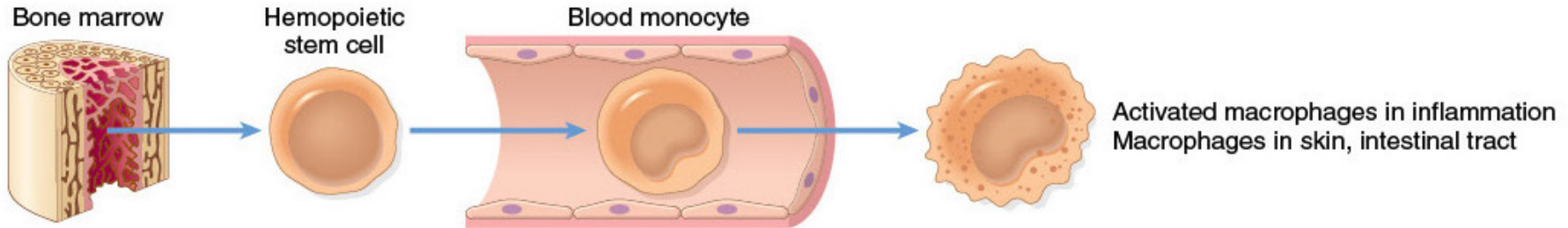
Tissue-resident macrophages



Macrophages respond to conditions in the tissue to regulate homeostasis and pathogen clearance

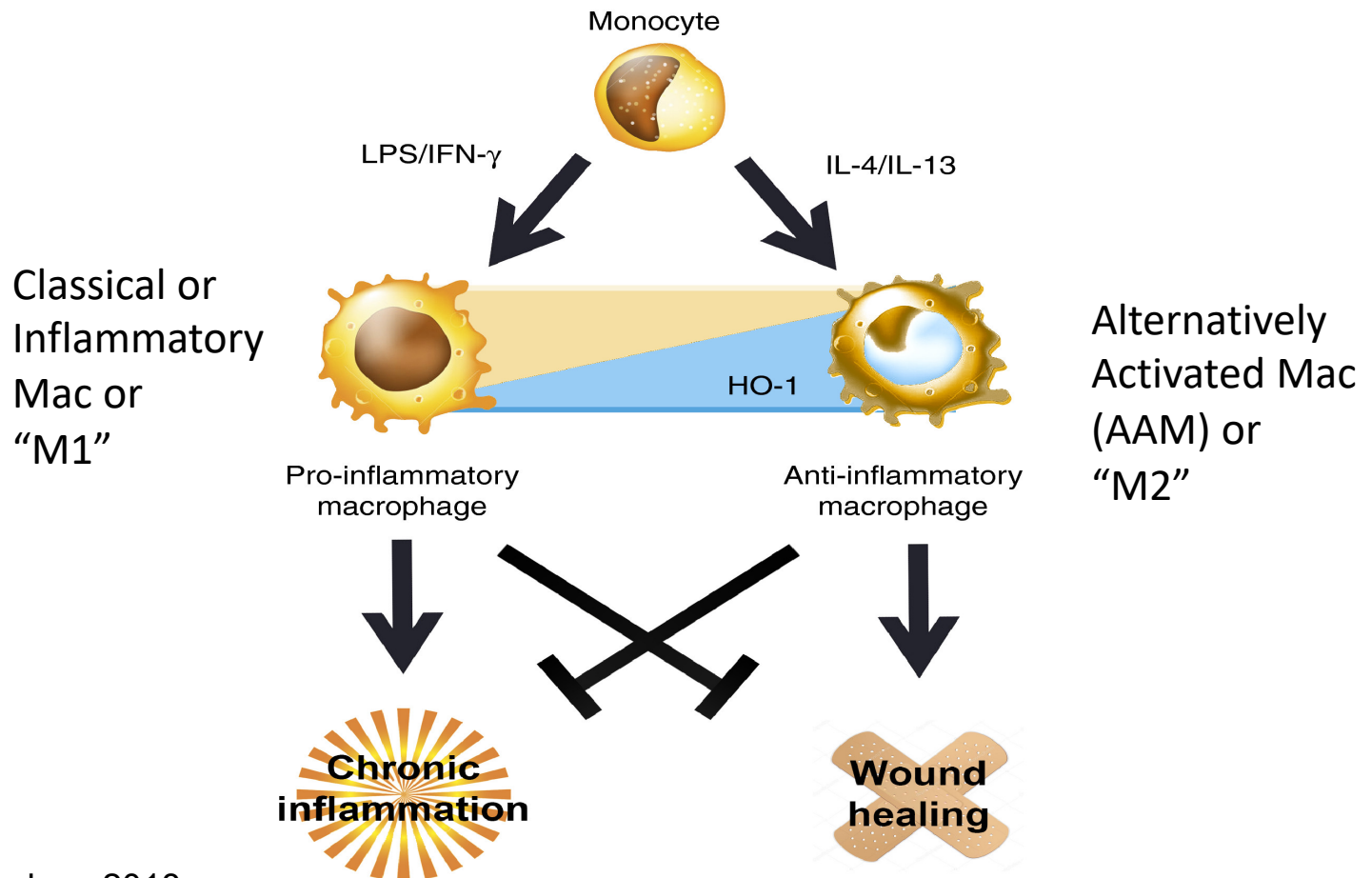

First responders recruit

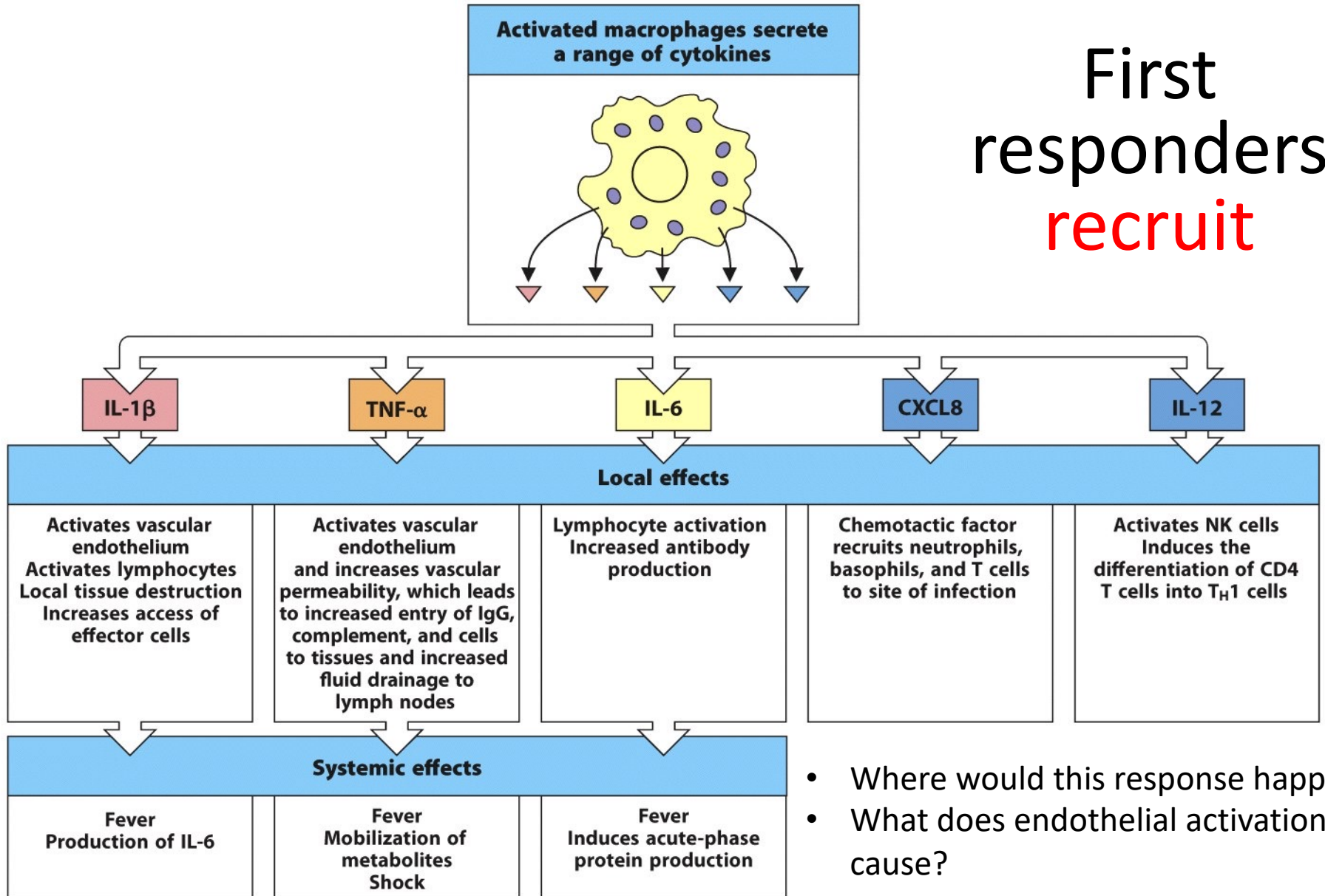

- Where would this response happen?
- What does endothelial activation cause?

Figure 3.21 Janeway's Immunobiology, 8ed. (© Garland Science 2012)

Microbes bind to phagocyte receptors

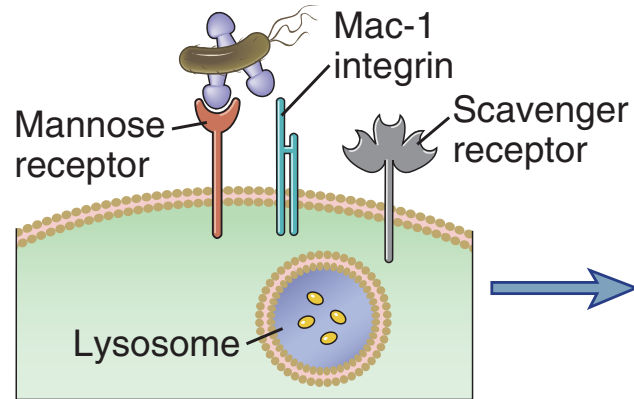

Phagocyte membrane zips up around microbe

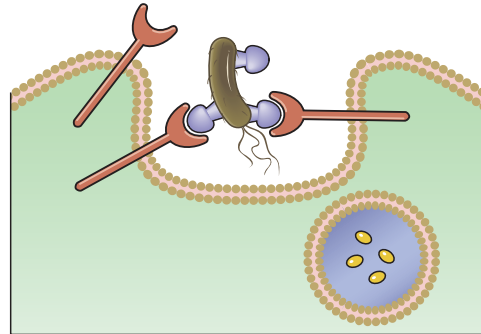

Microbe ingested in phagosome

Fusion of phagosome with lysosome

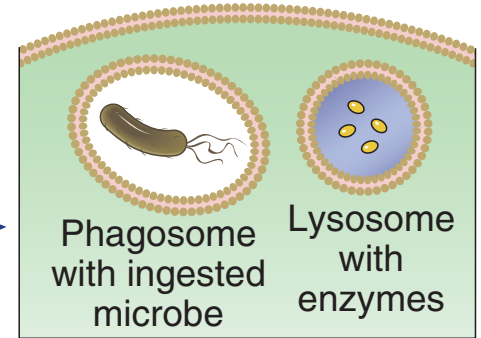

Activation of phagocyte

Killing of microbes by ROS, NO, and lysosomal enzymes in phagolysosomes

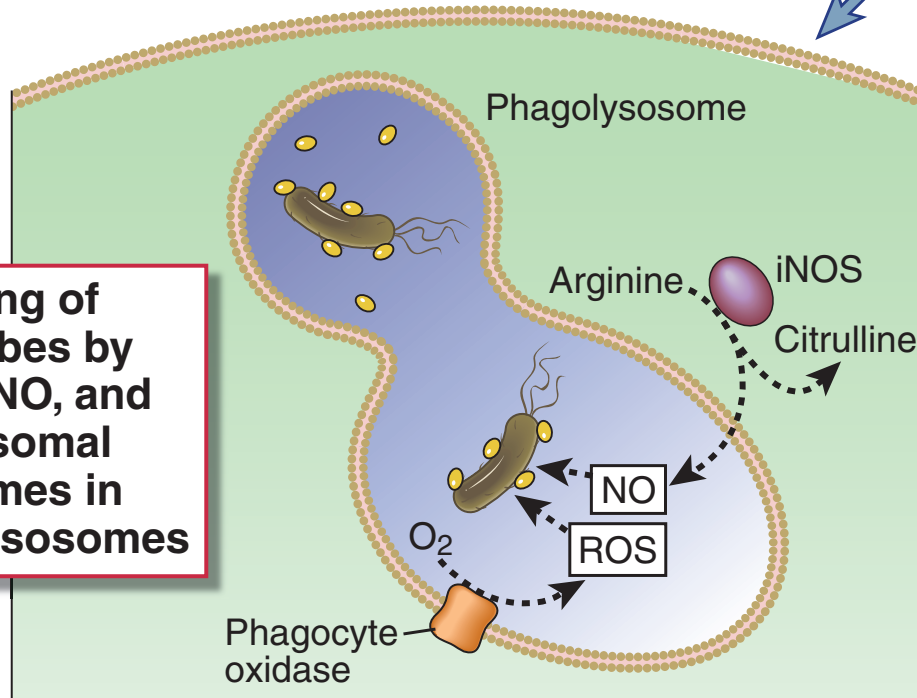

**First responders
clear pathogens
and dead cells**

Chronic Granulomatous Disease (CGD)

- Recurrent bacterial infection
- Granulomas of skin, liver, lungs, lymph nodes observed
- Gene defect:
 - gp91 phox (X-Linked)
 - p22 phox (Autosomal Recessive)
 - p47 phox (Autosomal Recessive)
 - p67 phox (Autosomal Recessive)
- Phagocytic cells ingest but do not kill bacteria due to failure to form oxygen radicals

What is wrong with this picture? →

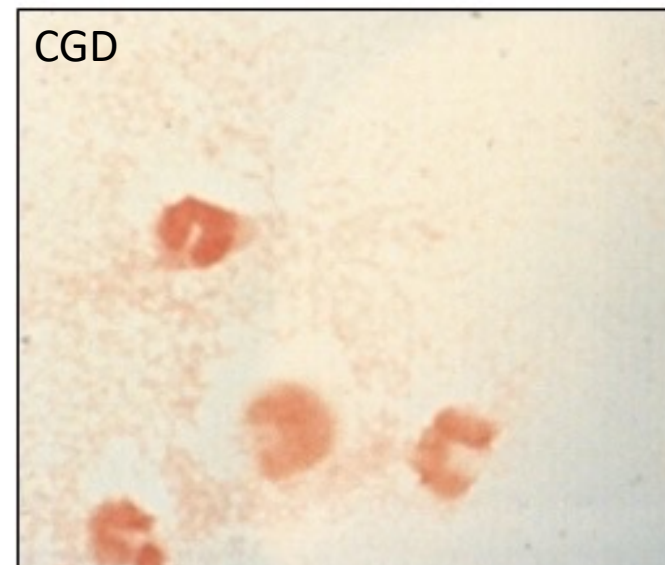
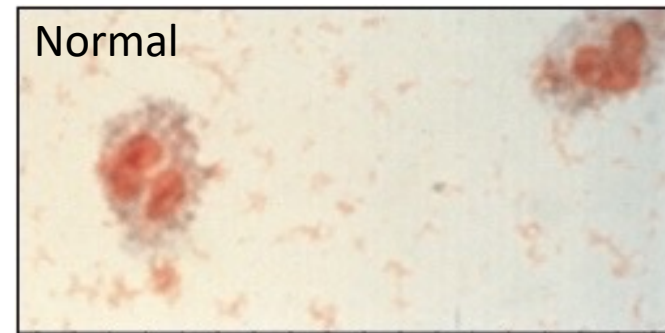

IFN γ and macrophage activation

- Mendelian susceptibility to mycobacterial disease (MSMD) – Ifn γ -mediated protection (IL-12, Ifn γ , Stat1 defects)
 - Failure of CD4+ T cells to activate macrophage killing of intracellular bacteria

- TNF blockers might interfere with this process...
- Anti-IFN γ autoantibodies can do the same

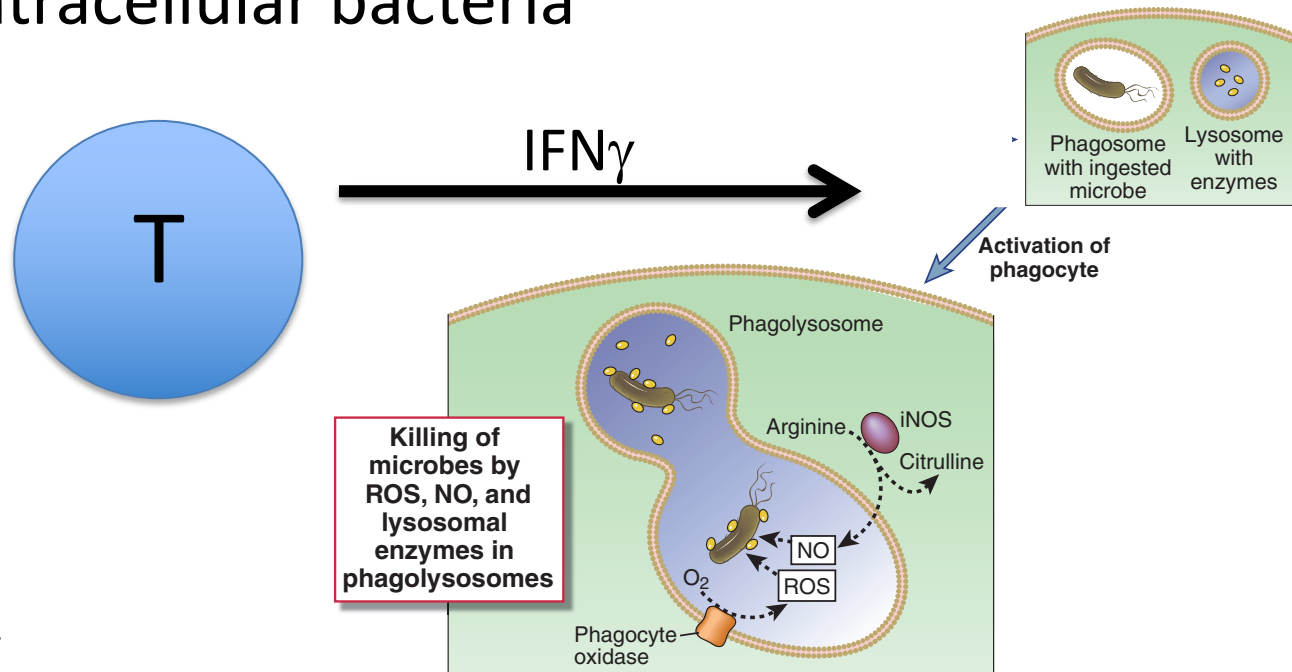

Questions?

Neutrophils engulf and kill the microbes to which they bind

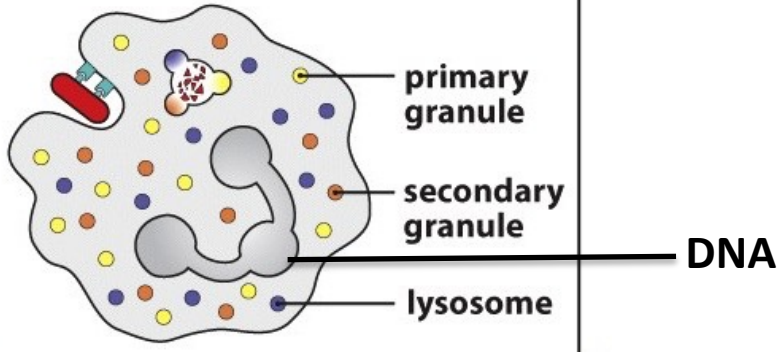

Neutrophil NETs

- Neutrophil extracellular traps
- NETosis with cell death traps microbes
 - Extrusion of chromatin decorated with antimicrobial molecules (e.g., elastase, MPO)
 - Suicidal vs. vital NETosis
 - Limited other cells types can also engage this pathway
- Role in driving autoimmunity?

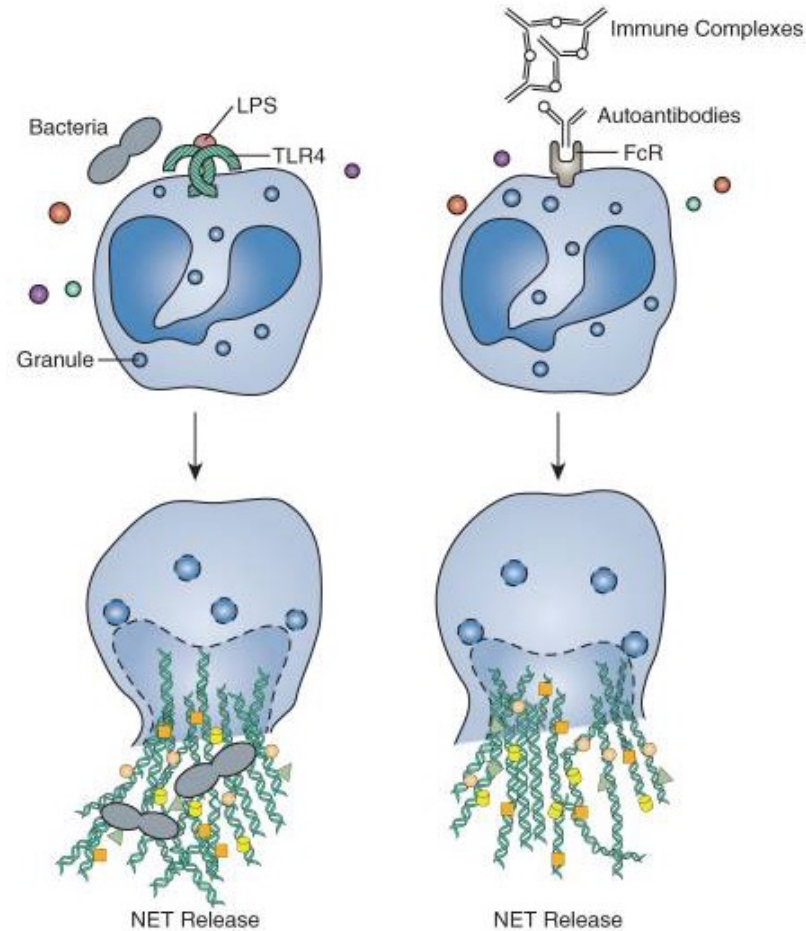

NK Cells (ILC1)

- Different from NKT cells
- Germline encoded receptors
- Kill cells that are missing “stop” signals
 - Inhibitory receptors
 - KIRs
- Kill cells that express foreign or stress signals
 - Activating receptors
 - CLRs
 - NKG2D
 - FcγRIII (CD16)
- Infections
- Tumors

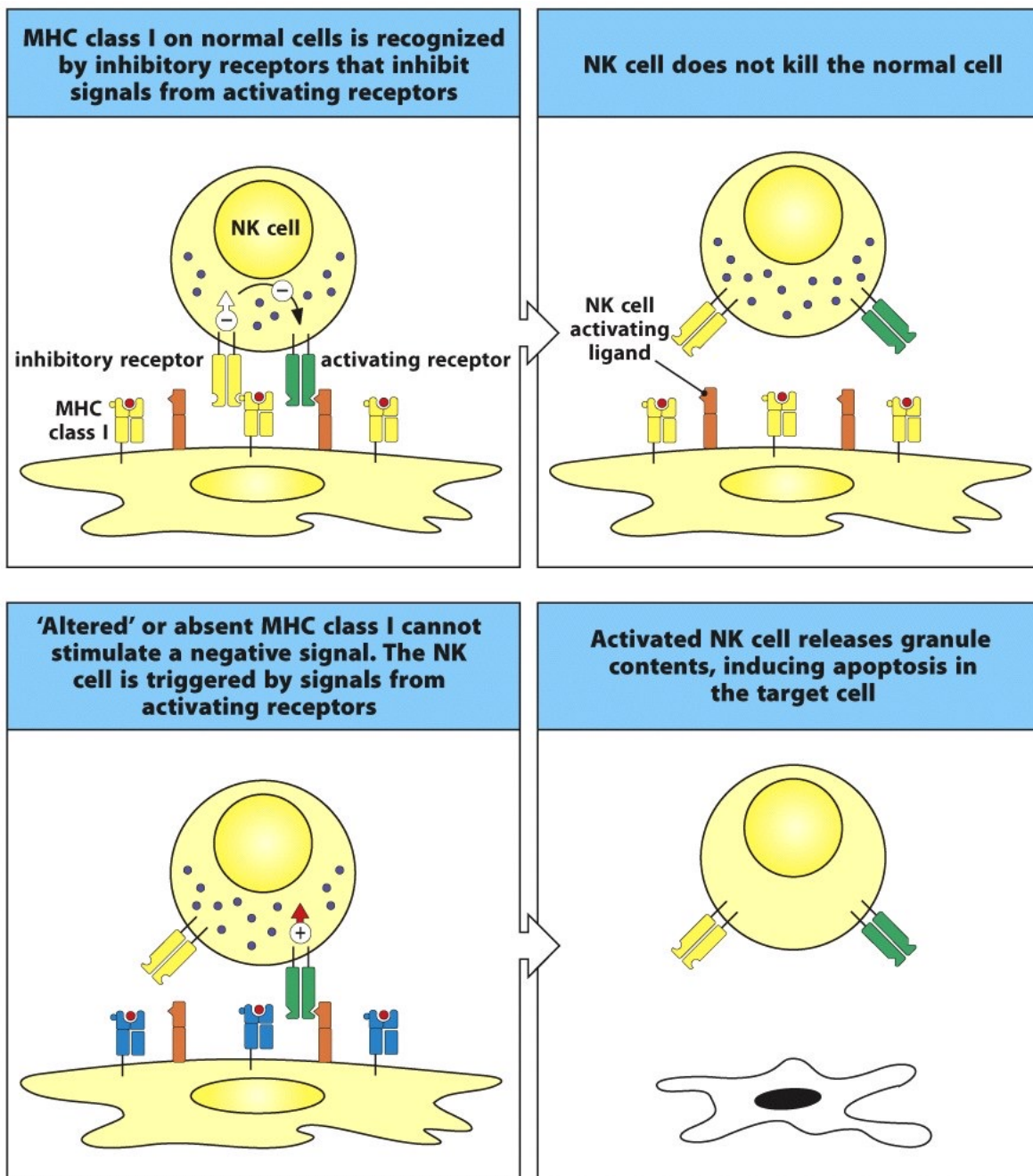
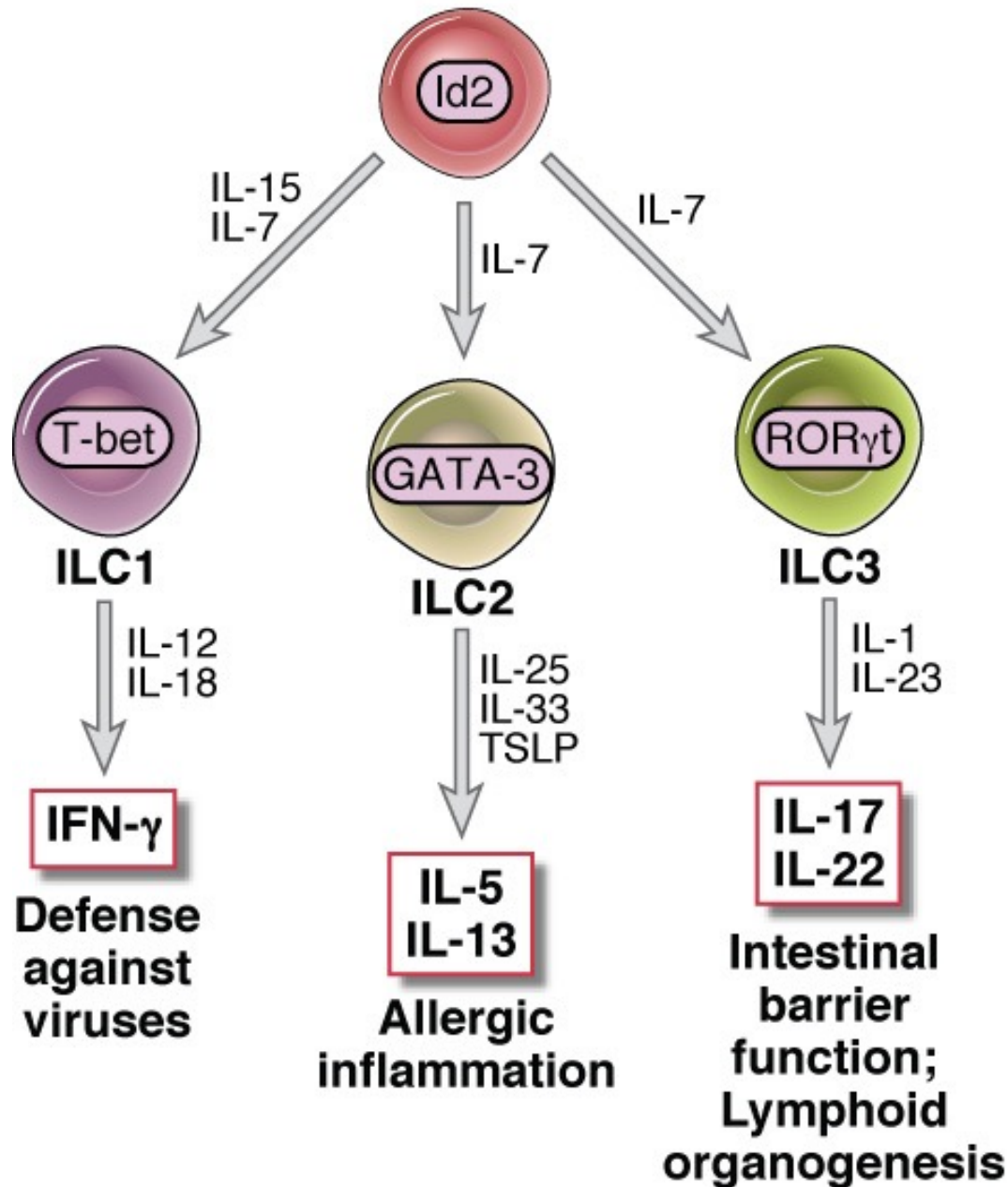

Figure 3.31 Janeway's Immunobiology, 8ed. (© Garland Science 2012)

Innate lymphoid cells



ILCs make many of the same cytokines as T cells but lack TCRs

May contribute to early cytokine responses in host defense and inflammatory diseases

Questions?

DCs & the next phase of immunity

DCs survey for pathogens or host damage (via PRRs) and respond by processing antigens and providing “second signals”

T cell priming requires 2 signals to avoid anergy: antigen (constant) + co-stimulation (activated DC)

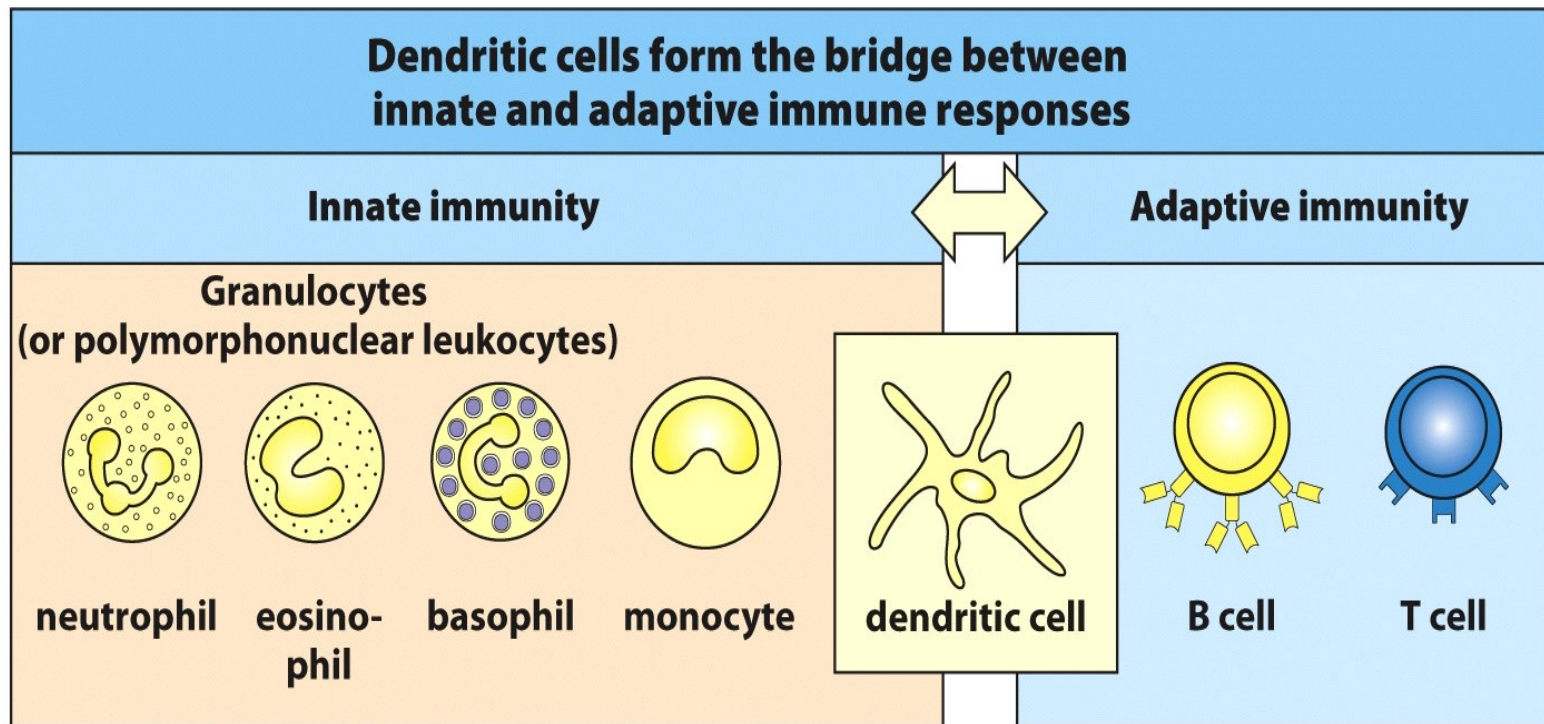

Figure 1.5 Janeway's Immunobiology, 8ed. (© Garland Science 2012)

DCs = translators between innate & adaptive immunity

Why are DCs the most efficient APCs for initiating immune responses?

Will discuss in a few slides

DC and related subsets

Immature vs mature DCs
Naïve vs activated DCs

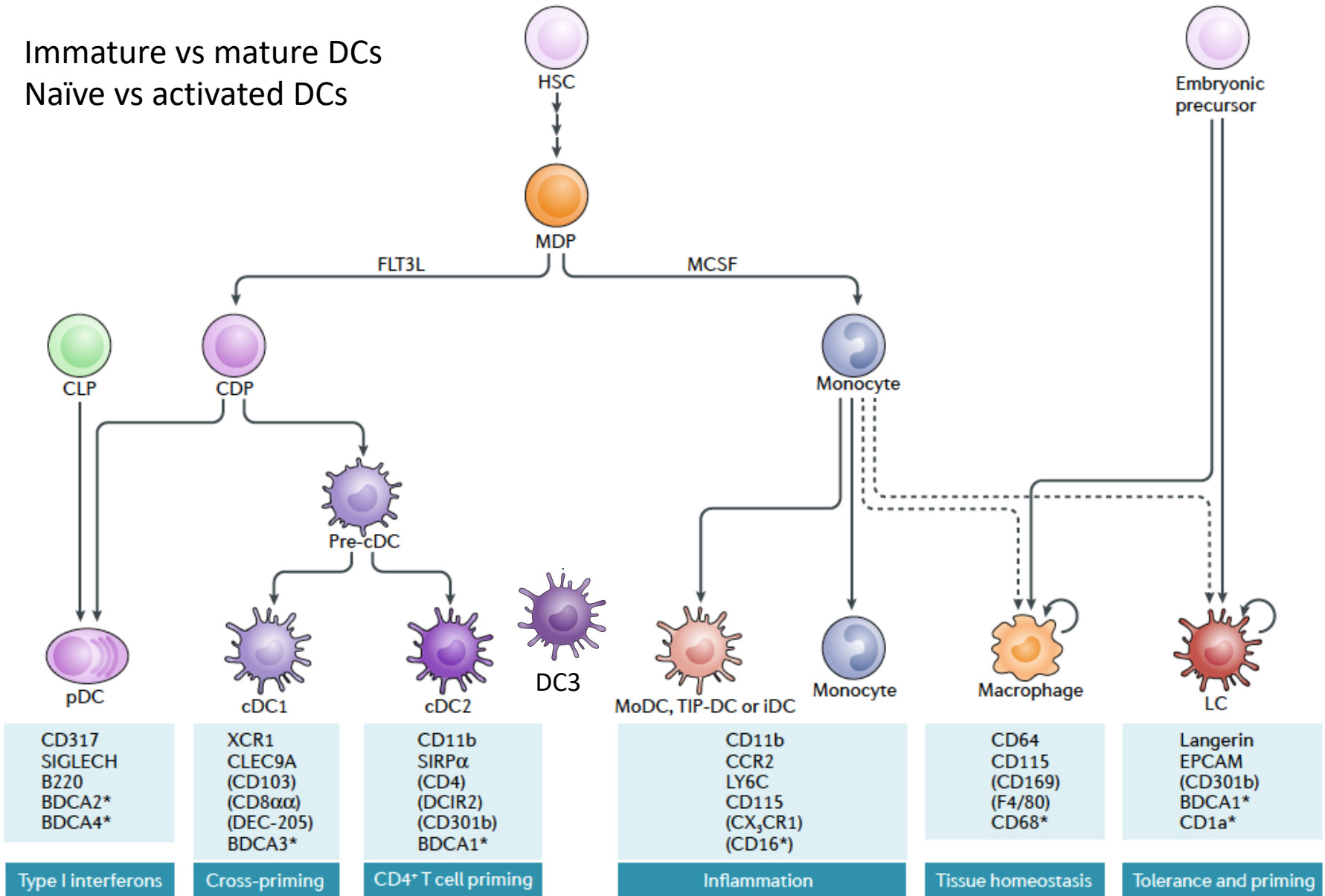

DCs present antigen to CD4+ and CD8+ T cells through distinct pathways

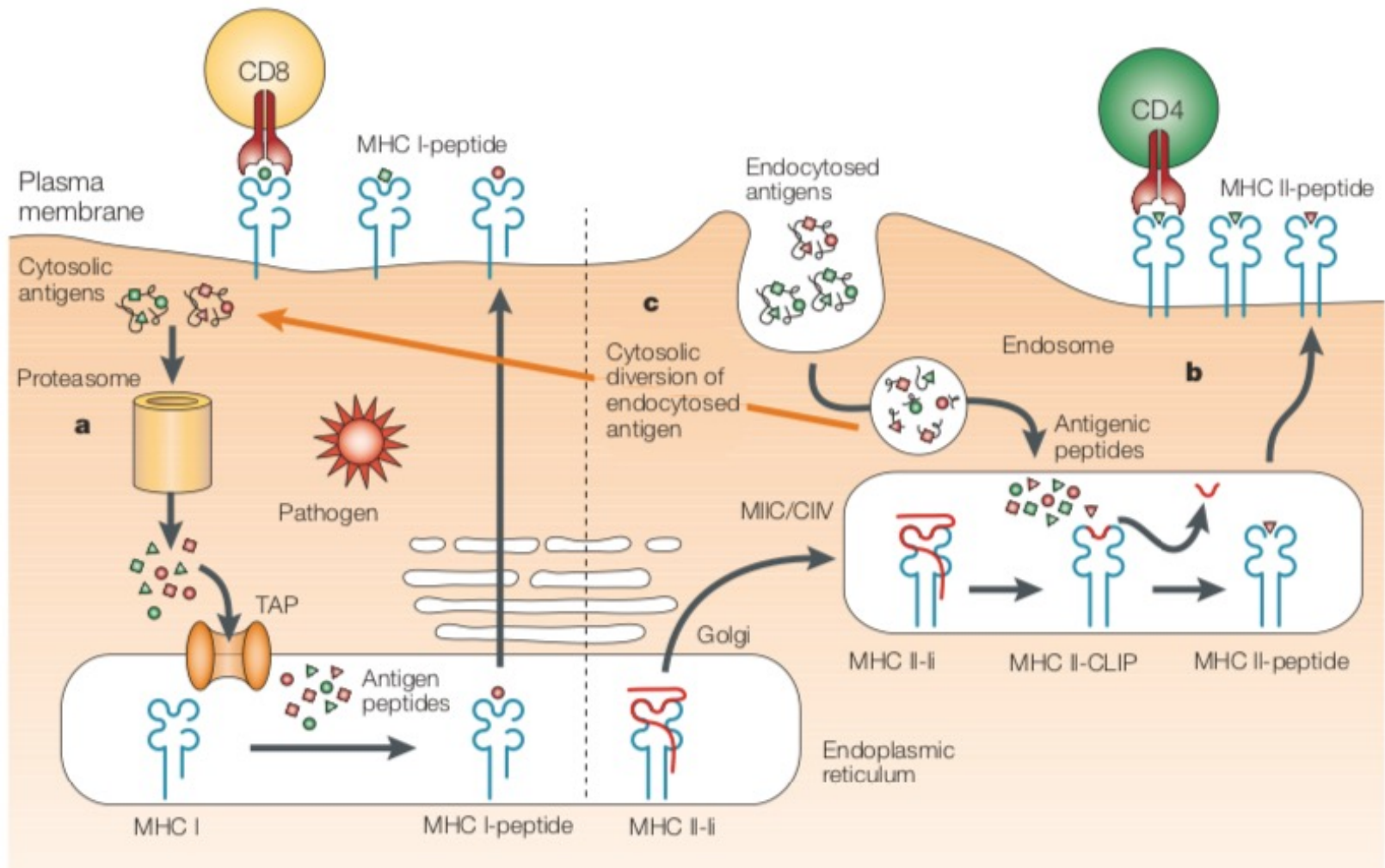

PRR stimulation induces DC activation ("maturation")

Immature DC

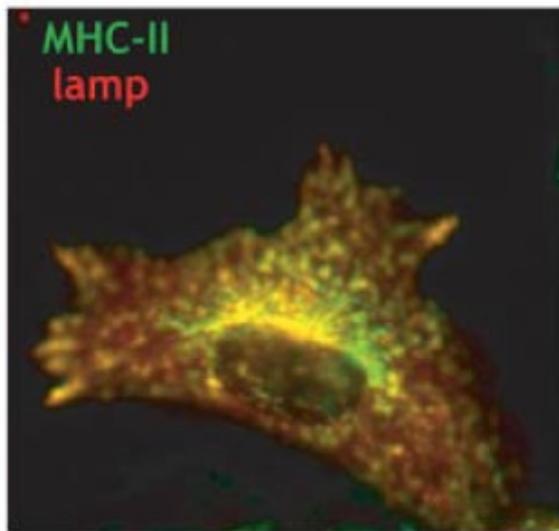

Peripheral and lymphoid tissues
Highly endocytic
Low surface MHC-II and costimulators
Antigen accumulation

Mature DC

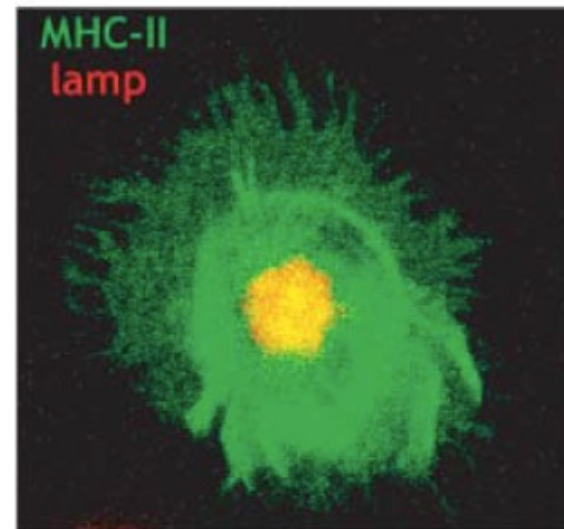

Lymphoid tissues
Endocytosis reduced
High surface MHC-II and costimulators
T cell stimulation

The innate immune system provides second signals required for lymphocyte activation

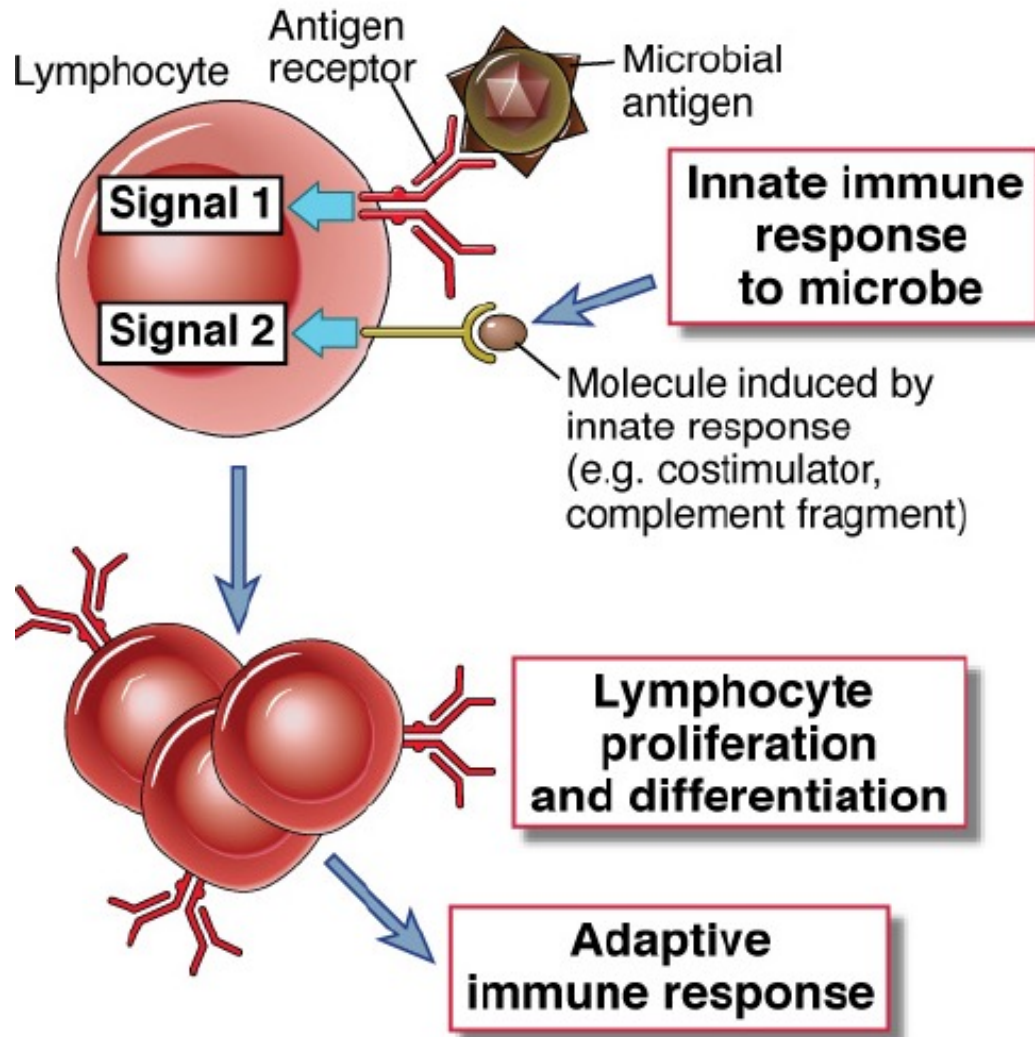

2nd signals for B cells:
CR2/CD21: Activated C'
TLRs: PAMPs

2nd signals for T cells:
*CD28: B7 family members
(CD80/B7.1, CD86/B7.2)*
ICOS: ICOSL
OX40: OX40L
CD137: 4-1BBL

Inhibitory signals for T cells:
PD1: PDL1, PDL2
CTLA4: CD80, CD86

Capture and presentation of antigens by dendritic cells

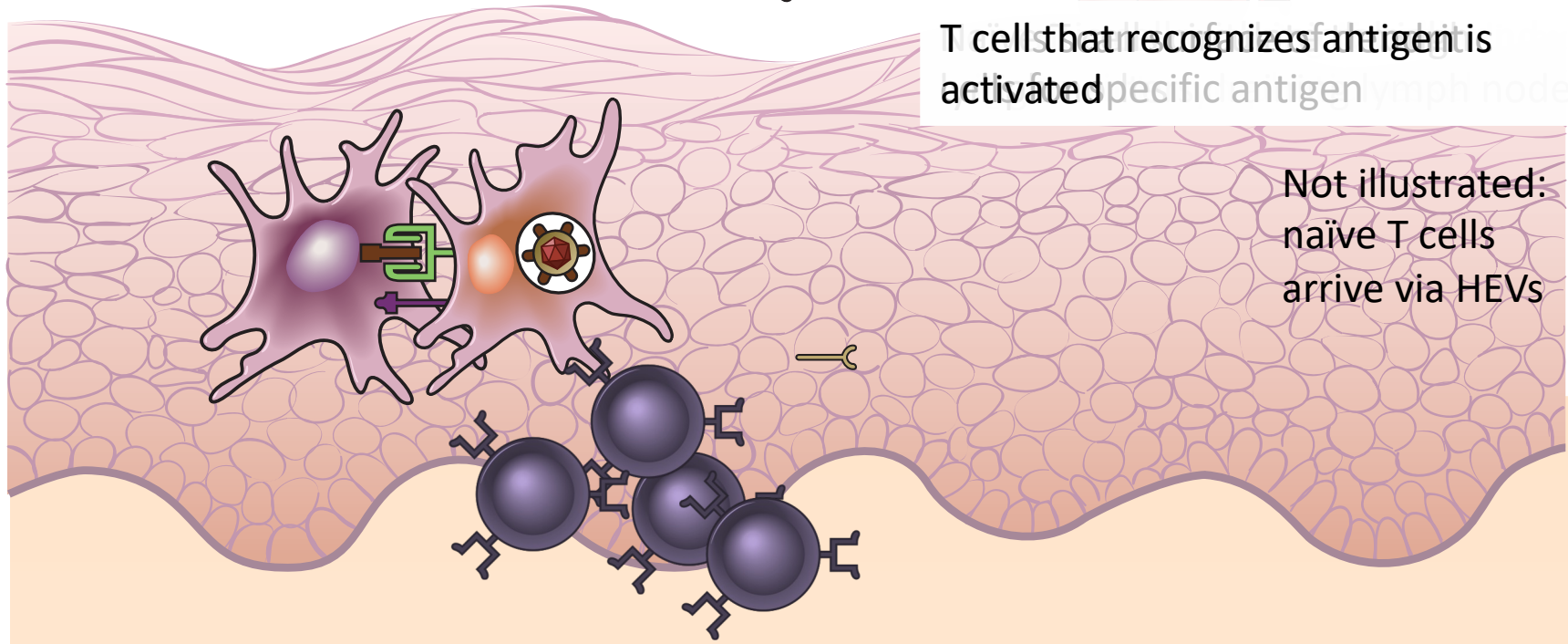

T cell that recognizes antigen is activated
specific antigen lymph node

Not illustrated:
naïve T cells
arrive via HEVs

PRR activation →

- Ag processing/presentation on MHC
- Co-stimulatory molecule expression
- CCR7 expression → follow a gradient of CCL19/CCL21
- DCs then die (cellular timer)

Why are DCs the most efficient APCs for initiating immune responses?

- **Receptors for capturing and reacting to microbes:** Toll-like receptors, complement receptors, FcRs, etc.
 - Unique to DCs?
- **Express co-stimulatory molecules:** signal 2 for T cells
 - Unique to DCs?
- **Location:** at sites of microbe entry (epithelia) and ability to interact with NAÏVE T cells
 - Why not activate naïve T cells in the skin/lung/gut?
 - Macrophages, monocytes, B cells?
 - Why would macrophages/monocytes express signal 1 & 2 in tissues?
 - DC migration is a critical step in T cell priming
 - How do DCs find the LN?



Innate instruction of adaptive immunity: implications

Once this principle was understood, the role of adjuvants could be explained

- HBV vaccine : subunit and adjuvant
- *Adjuvare* = to help
- Hundreds of different adjuvants
 - CFA, Aluminum hydroxide, MF-59 (Squaler (Alum+MPL)

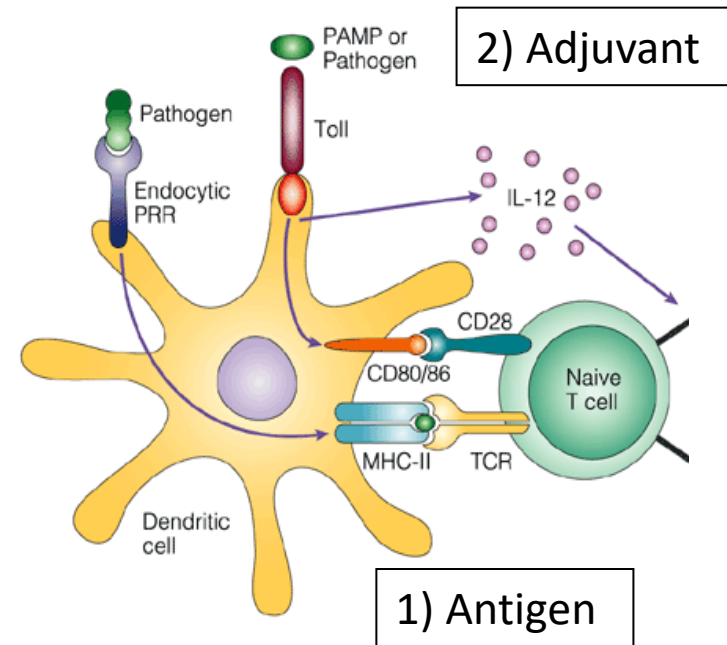

Medzhitov, 2001

Discussion

- Would an INACTIVE influenza virus activate innate → adaptive?
- How is innate immune activation initiated to tumor or alloantigens?

Questions?

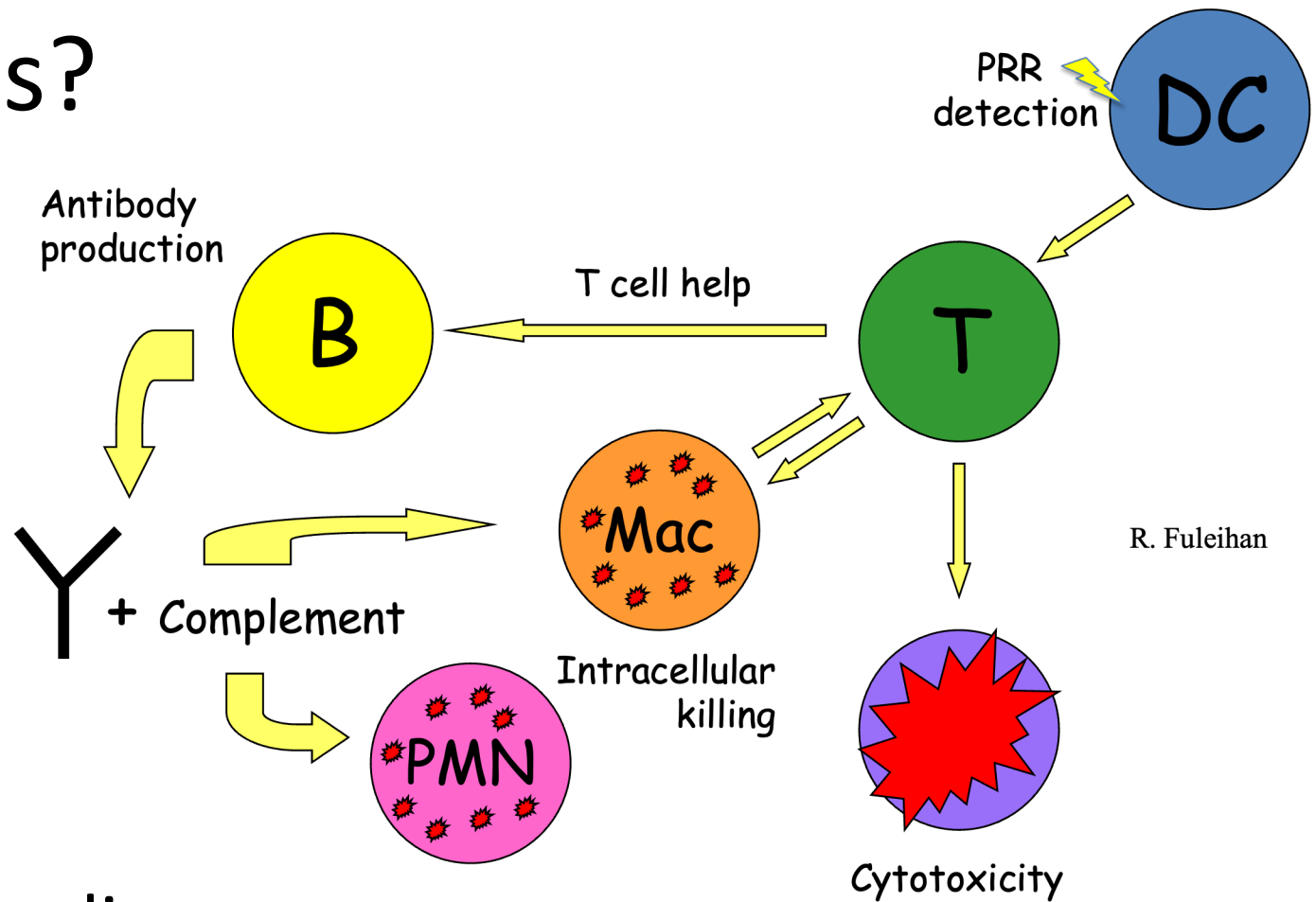

- Further reading

- Abbas, Lichtman & Pillai Cellular & Molecular Immunology
- Janeway's Immunobiology